



Alfa Laval in brief

Alfa Laval is leading global provider of specialized products and engineering solutions.

Our equipment, systems and services are dedicated to assisting customers in optimizing the performance of their processes. Time and time again.

We help them heat, cool, separate and transport products such as oil, water, chemicals, beverages, foodstuff, starch and pharmaceuticals.

Our worldwide organization works closely with customers in almost 100 countries to help them stay ahead.

Unit Coolers



Industrial unit coolers • Ceiling unit coolers • Commercial unit coolers



Air Units

- A Commercial Unit Coolers
- B Ceiling Unit Coolers
- C Industrial Unit Coolers

General Contents	4
<hr/>	
A Compact	6
Slim	6
AlfaCubic	9
Top	12
<hr/>	
B BFG/BFB	14
TFG	14
Big Top	18
<hr/>	
C AirMax	20
ISC	40

General Contents



- A Commercial Unit Coolers
- B Ceiling Unit Coolers
- C Industrial Unit Coolers

General features

Most of our unit coolers are available in the following versions:

- Direct expansion evaporators
- Brine unit coolers
- Pump ammonia evaporators

Certifications and reliability

About the performance, all DX unit coolers are certified by Eurovent "Certify All". The Alfa Laval quality system is in accordance with ISO 9001. All products are manufactured according with CE rules.



Fin spacing

According to our experience the fin spacing is related to the goods stored and the air room temperature, as follows:

Series	Green Line	Red Line	Blue Line
Product	Fruits / Vegetable	Meet / Fish	Frozen food
Room temperature	10 ÷ 0°C	0 ÷ -7°C	-18 ÷ -25°C
Fin spacing	3 ÷ 4,5mm	5 ÷ 6mm	≥ 7mm

Capacity

The standard conditions are according to EN 328. The cooling capacities announced in the catalogue are the nominal capacities Q_n (wet conditions) in accordance with the Eurovent rules. As standard capacities Q_{st} (dry conditions), the nominal capacities at standard conditions are calculated in accordance with the following relationship:

$$Q_n = Q_{st} \times \text{Wet Coil Factor}$$

Standard conditions	Air Inlet Temp. °C	Evaporation Temp. (Dew point) °C	R.H.	Wet Coil Factor
SC1	10	0	85%	1,35
SC2	0	-8	85%	1,15
SC3	-18	-25	95%	1,05
SC4	-25	-31	95%	1,01

The nominal capacities are calculated with refrigerant R404A, for different refrigerants shall be used the following factors:

Refrigerant	SC1	SC2	SC3	SC4
R134a	0,93	0,91	0,85	-
R22	0,95	0,95	0,95	0,95
R404A/R507	1	1	1	1

See below the fin material factors:

Fin Material	Factor
Aluminium	1
Coated Aluminium	0,97
Copper	1,03

Notes for cold room planning

The diagram below shows the relationship of cooling capacity to the cold room volume, considering the following parameters:

- a) Insulation thickness: 70 mm for positive temperature
100 mm for negative temperature
- b) Density of polyurethane: 40 kg/m³
- c) Daily load movement: 10% of the store load capacity
- d) Goods introduced in the store room at 25°C for positive temperature, goods already frozen at -7°C for negative temperature.
- e) Cooling time: 20 hours.

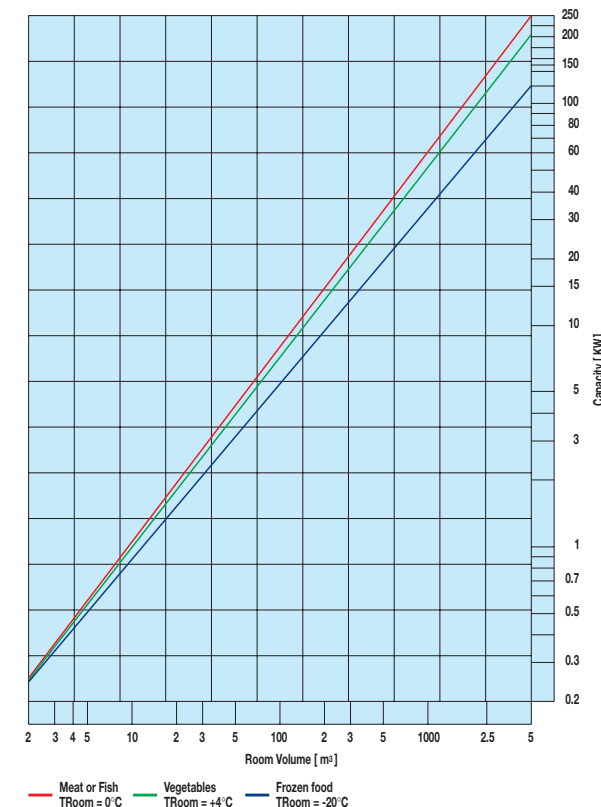

Air throw

The announced values are according to Cecomaf GT6-001 based on a final air velocity of 0.25 m/s.

Air relative humidity and working ΔT

The cold room hygrometric conditions are defined by the temperature and the working ΔT. At positive cold room temperatures ΔT has an influence on the relative humidity (HR).

Noise level

The sound pressure level is weighted average of the values measured at 5 m. The sound absorption of the room can influence the sound pressure level ± 3 dB(A). For distance different to 5 m, the noise pressure level must be corrected as follows:

m	1	2	3	4	5
dB(A)	6	4	2	1	0

Defrost

All our unit coolers are available with several kind of defrost systems. If the room temperature is lower than 2°C, a unit with defrost is necessary.

Test and cleaning

The coils are cleaned with perchloroethylene and dehydrated in order to eliminate any trace of oil.

Each heat exchanger undergoes a pressure and leaking test with dry air at 30 bar, and finally supplied with a nitrogen precharge.

Guarantee

All our products are guaranteed against defects for a period of 24 months from date of shipment. If the defect should develop within the guarantee period, return the equipment or the part free to our factory where they will be repaired or replaced, according to our judgment. We don't take responsibility for damage caused by misuse or inappropriate installation of our products. Brochure subject to technical changes without prior notice.



Compact



CGL



Slim



SGL • SBL

Application

These compact units are designed for use in both walk-in and reach-in cabinet and in small cold rooms from 2 to 20 m³. Units designed for an easy maintenance with immediate access to the inspection areas.

This series is available as DX evaporator.

Coil

Coil manufactured from corrugated aluminium fins and copper tubes nominal diameter 10 mm.

Standard fin spacing 4.2 mm.

Frame made from aluminium sheets.

Casing

It's manufactured from anti-shock plastic materials, suitable for applications where a high degree of hygiene is required.

Fans

Single-phase motor 230V-50Hz, 4 poles, Protection class IP 44 according to DIN 40050. Low power consumption. Integrated thermal protection by thermo contacts. This provides reliable protection against thermal overload.

Defrost

As optional is available electric defrost with assembling kit provided.

Optional

- Drain-pipe flexible electrical heater
- Coil epoxy coating

Application

These units are designed for specific use in small cold rooms at positive and negative temperature with volume from 4 to 70 m³. Units designed for an easy maintenance with immediate access to the inspection areas.

This series is available as DX evaporator.

Coil

Coil manufactured from corrugated aluminium fins and copper tubes nominal diameter 10 mm.

Standard fin spacing: 3 mm

4/8 mm (dual fin spacing)

Frame made from aluminium sheets.

Casing

It's manufactured from anti-shock plastic materials, suitable for applications where a high degree of hygiene is required. Innovative drip tray with hinges for a easier opening.

Fans

Single-phase motor 230V-50Hz, 4 poles, Protection class IP 44 according to DIN 40050. Low power consumption. Integrated thermal protection by thermo contacts. This provides reliable protection against thermal overload.

Defrost

As optional is available electric defrost with assembling kit provided.

Optional

- Drain-pipe flexible electrical heater
- Coil epoxy coating

Compact CGL

Model	Capacity * SC2	Capacity * SC3	Air flow	Air throw	Surface	Tube volume	Defrost **	Fan motors	Power consump.	Current consump.	Noise	Dimensions		Connections		Weight
	kW $\Delta T=8K$ Tev=-8°C	kW $\Delta T=7K$ Tev=-25°C	m ³ /h	m	m ²	dm ³	W E	n° x Ømm	W	A	dB(A) (5m)	mm A	mm B	mm inlet	mm outlet	kg
CGL1	0,5	0,41	490	6	1,7	0,65	250	1x230	42	0,21	48	580	455	10	10	5,5
CGL2	0,62	0,5	440	5,5	2,3	0,87	250	1x230	42	0,21	48	580	455	10	10	6
CGL3	1,07	0,85	980	6	3,4	1,2	500	2x230	84	0,42	51	1020	1020	1/2"SAE	16	10,5
CGL4	1,24	1,01	880	5,5	4,6	1,6	500	2x230	84	0,42	51	1020	1020	1/2"SAE	16	11
CGL5	1,34	1,09	790	5	5,7	2	500	2x230	84	0,42	51	1020	1020	1/2"SAE	16	11,5
CGL6	1,51	1,22	710	4,5	6,8	2,4	500	2x230	84	0,42	51	1020	1020	1/2"SAE	16	12

Slim • SGL • SBL

Model	Capacity * SC2	Capacity * SC3	Air flow	Air throw	Surface	Tube volume	Defrost **	Fan motor	Power consump.	Current consump.	Sound Level	Dimensions		Connections		Weight
	kW $\Delta T=8K$ Tev=-8°C	kW $\Delta T=7K$ Tev=-25°C	m ³ /h	m	m ²	dm ³	W E	n° x Ømm	W	A	dB(A) (5m)	mm A	mm B	mm inlet	mm outlet	kg
SGL11	1,03	0,81	900	7	5,8	1,3	550	1x300	105	0,75	46	800	570	1/2"SAE	12	12
SGL12	1,2	0,99	850	7	7,7	1,8	780	1x300	105	0,75	46	800	570	1/2"SAE	12	13,5
SGL13	1,75	1,42	1500	9	8,5	1,9	800	2x300	210	1,5	49	1080	850	1/2"SAE	12	19
SGL14	2,01	1,66	1400	9	11,4	2,5	1130	2x300	210	1,5	49	1080	850	1/2"SAE	22	21
SGL15	2,57	2,1	2200	11	12,8	2,7	1190	3x300	315	2,25	51	1520	1290	1/2"SAE	22	29
SGL16	3,07	2,45	2100	11	17	3,7	1650	3x300	315	2,25	51	1520	1290	1/2"SAE	22	31,5

SBL21	0,74	0,6	1050	7,5	3,7	1,3	550	1x300	105	0,75	46	800	570	1/2"SAE	12	10,5
SBL22	0,95	0,79	1000	7,5	5,2	1,8	780	1x300	105	0,75	46	800	570	1/2"SAE	12	12
SBL23	1,25	1,03	1751	9,5	5,5	1,9	800	2x300	210	1,5	49	1080	850	1/2"SAE	12	17
SBL24	1,42	1,18	1649	9,5	7,6	2,5	1130	2x300	210	1,5	49	1080	850	1/2"SAE	22	18,5
SBL25	1,71	1,41	2500	11,5	8,2	2,7	1190	3x300	315	2,25	51	1520	1290	1/2"SAE	22	26
SBL26	2,23	1,82	2401	11,5	11,4	3,7	1650	3x300	315	2,25	51	1520	1290	1/2"SAE	22	28

* Nominal capacity according to ENV328 and Eurovent rules ($\Delta T1 = T_{INair} - T_{ev}$)

From models CGL4, SGL12 and SBL22 an expansion valve with external equalizer must be used.

** Defrost: E = Electric heaters in the coil. As option electric heater RS = 70 W in drain-pipe .

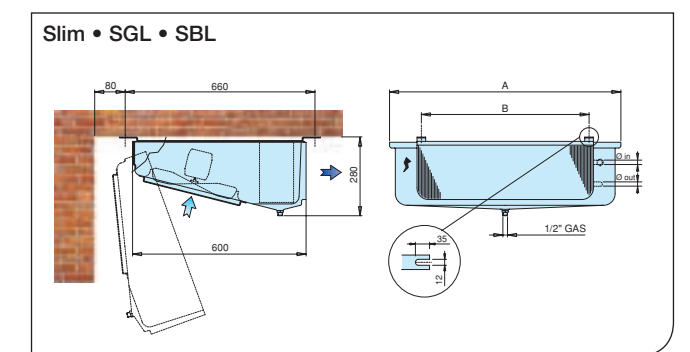
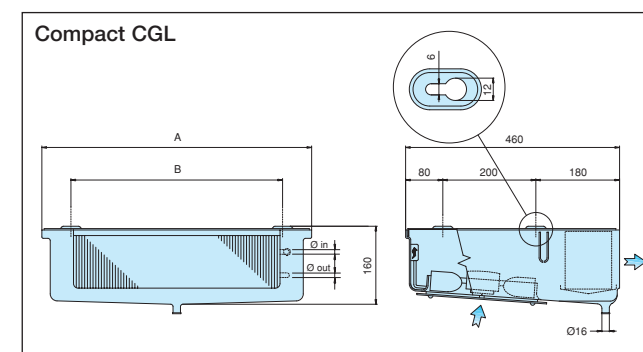

Selection Chart

For an easy thermal selection, we suggest to use our program Palladio or the following diagrams valid for R404A / R507, DX evaporator, R.H. = 80 ÷ 90 % and $\Delta T_{supH} = 5$ K:

Compact CGL

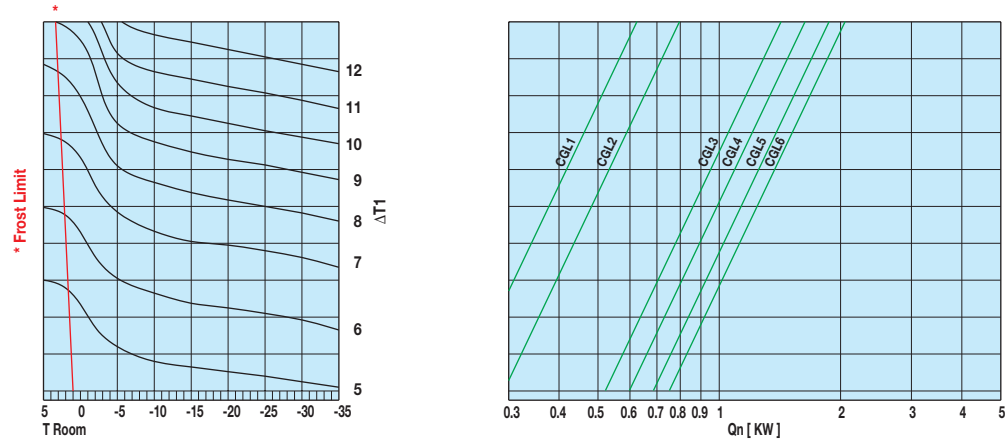

Slim SGL • SBL

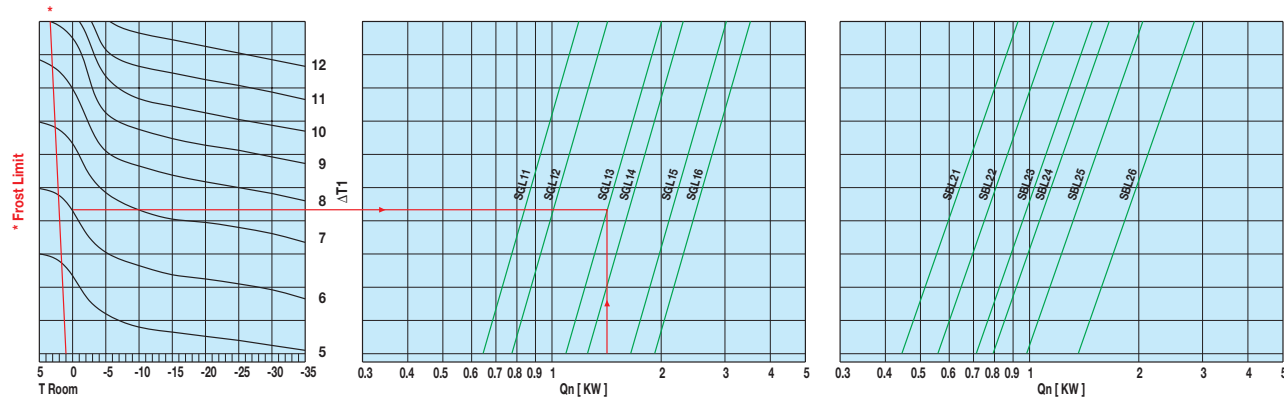

Series	CGL	SGL	SBL
Product	Fresh and frozen goods	Fresh goods	Frozen goods
Room temperature Tc	10 ÷ -20°C	10 ÷ 0°C	-18 ÷ -25°C
Fin spacing	4,2 mm	3 mm	4/8 mm

Ordering Code	
Model (i)	CGL Compact unit cooler SGL Slim unit cooler
Defrost (ii)	A = Air • E = Electric

Example: SGL12 A (i)



AlfaCubic



GL • RL • BL

Application

Units designed for use in small and medium cold rooms from 10 to 400 m³. Models designed for an easy maintenance with immediate access to inspection areas. This series is available as: DX evaporator, NH₃ pump evaporator and Brine unit cooler.

Coil

Coil manufactured from corrugated aluminium fins and copper rippled tubes nominal diameter 12 mm for DX evaporator and smooth tubes nominal diameter 12 mm for Brine and 16 mm stainless steel tubes for NH₃ units.

Casing

It's manufactured from pre-painted aluminium sheets RAL 9010, protected by plastic film suitable for heavy conditions.

Fans

Single-phase motors 230V-50Hz, 4 poles, protection class

IP54 according to DIN 40050. Low power consumption. Integrated thermal protection by thermo contacts. This provides reliable protection against thermal overload.

Defrost

As optional are available the following defrost: electric, hot gas, hot gas in the coil and electric in the drip tray.

Optional

- Drain-pipe flexible electrical heater
- Coil epoxy coating
- Cataphoresis treatment
- Stainless steel tubes
- Fan ring heater
- Motors 3ph-400V-50Hz, 4 poles
- Motors 1ph-230V-50Hz, 6 poles
- Re-heating coil

AlfaCubic GL

Model	Capacity SC2	Capacity SC3	Air Flow	Air Throw	Surface	Tube volume	Defrost			Fan motors	Power consump.	Current consump.	Noise	Dimensions			Connections		Weight
	kW	kW					W	W	W					n° x Ømm	W	A	dB(A)	mm	
Fin spacing 4,5 mm	ΔT= 8K Tev= -8°C	ΔT= 7K Tev= -25°C					E	HG+E	FRH				(5m)	A	B	C	inlet	outlet	
GLE251A4	2,18	1,72	1556	13	12,8	1,33	1050	270	300	1x250	120	0,53	59	840	395	460	1/2"SAE	12	16
GLE251B4	2,7	2,01	1446	12	19,2	2	1440	270	300	1x250	120	0,53	59	840	395	460	1/2"SAE	12	18
GLE252A4	4,02	2,3	3112	15	25,6	2,67	2100	540	600	2x250	240	1,06	62	1340	395	460	1/2"SAE	22	25
GLE252B4	5,51	4,16	2893	14	38,4	4	2880	540	600	2x250	240	1,06	62	1340	395	460	1/2"SAE	22	30
GLE253A4	6,57	4,87	4668	16	38,4	4	3160	800	900	3x250	360	1,59	64	1840	395	460	1/2"SAE	22	36
GLE253B4	7,6	5,14	4339	15	57,7	6,01	4340	800	900	3x250	360	1,59	64	1840	395	460	1/2"SAE	22	42
GLE351A4	3,45	2,78	2375	14	21,4	2,22	1440	270	300	1x350	160	0,7	52	840	585	460	1/2"SAE	22	30
GLE351B4	4,39	3,39	2219	13	32	3,34	1830	270	300	1x350	160	0,7	52	840	585	460	1/2"SAE	22	38
GLE352A4	7,05	5,53	4749	16	42,7	4,45	2880	540	600	2x350	320	1,4	55	1340	585	460	1/2"SAE	24	42
GLE352B4	8,64	6,39	4438	15	64,1	6,67	3660	540	600	2x350	320	1,4	55	1340	585	460	1/2"SAE	24	49
GLE353A4	10,58	8,18	7124	17	64,1	6,67	4340	800	900	3x350	480	2,1	57	1840	585	460	1/2"SAE	28	58
GLE353B4	13,2	10,05	6657	16	96,1	10,01	5520	800	900	3x350	480	2,1	57	1840	585	460	5/8"SAE	28	67
GLE354A4	14,11	10,79	9498	18	85,4	8,9	5710	1000	1200	4x350	640	2,8	58	2340	585	460	5/8"SAE	35	84
GLE354B4	17,45	13,03	8876	17	128,1	13,35	7280	1000	1200	4x350	640	2,8	58	2340	585	460	5/8"SAE	35	88
GLE401B4	6,2	4,88	3179	17	43,8	4,56	3600	450	350	1x400	190	0,8	56	910	685	630	1/2"SAE	24	45
GLE401C4	6,96	5,28	3015	16	58,4	6,09	4500	450	350	1x400	190	0,8	56	910	685	630	1/2"SAE	24	50
GLE402B4	12,63	9,71	6404	19	90	9,37	7200	900	700	2x400	380	1,6	59	1510	685	630	5/8"SAE	35	90
GLE402C4	14,28	10,98	6083	18	119,9	12,49	9000	900	700	2x400	380	1,6	59	1510	685	630	5/8"SAE	35	95
GLE403B4	18,98	14,48	9627	20	136,1	14,17	10000	1250	1050	3x400	570	2,4	61	2110	685	630	22	42	120
GLE403C4	21,33	16,14	9150	19	181,5	18,9	12500	1250	1050	3x400	570	2,4	61	2110	685	630	22	42	130

Model	Capacity SC2	Capacity SC3	Air Flow	Air Throw	Surface	Tube volume	Defrost			Fan motors	Power consump.	Current consump.	Noise	Dimensions			Connections		Weight
	kW	kW	m ³ /h	m	m ²	dm ³	W	W	W	n° x Ømm	W	A	dB(A)	mm	mm	mm	mm	mm	kg
Fin spacing 5,5 mm	ΔT= 8K Tev= -8°C	ΔT= 7K Tev= -25°C					HG+E	FRH				(5m)		A	B	C	inlet	outlet	
RLE251A55	1,82	1,45	1596	14	9,5	1,33	1050	270	300	1x250	120	0,53	59	840	395	460	1/2"SAE	12	15
RLE251B55	2,4	1,8	1499	13	14,2	2	1440	270	300	1x250	120	0,53	59	840	395	460	1/2"SAE	12	17
RLE252A55	3,52	2,45	3192	16	18,9	2,67	2100	540	600	2x250	240	1,06	62	1340	395	460	1/2"SAE	22	24
RLE252B55	4,86	3,72	2997	15	28,4	4	2880	540	600	2x250	240	1,06	62	1340	395	460	1/2"SAE	22	29
RLE253A55	5,6	4,25	4788	17	28,4	4	3160	800	900	3x250	360	1,59	64	1840	395	460	1/2"SAE	22	35
RLE253B55	6,87	4,79	4496	16	42,6	6,01	4340	800	900	3x250	360	1,59	64	1840	395	460	1/2"SAE	22	40
RLE351A55	2,86	2,32	2427	15	15,8	2,22	1440	270	300	1x350	160	0,7	52	840	585	460	1/2"SAE	22	29
RLE351B55	3,84	3	2295	14	23,6	3,34	1830	270	300	1x350	160	0,7	52	840	585	460	1/2"SAE	22	36
RLE352A55	5,91	4,7	4853	17	31,5	4,45	2880	540	600	2x350	320	1,4	55	1340	585	460	1/2"SAE	24	40
RLE352B55	7,68	5,77	4590	16	47,3	6,67	3660	540	600	2x350	320	1,4	55	1340	585	460	1/2"SAE	24	47
RLE353A55	8,94	7	7280	18	47,3	6,67	4340	800	900	3x350	480	2,1	57	1840	585	460	1/2"SAE	28	56
RLE353B55	11,66	8,99	6886	17	70,9	10,01	5520	800	900	3x350	480	2,1	57	1840	585	460	5/8"SAE	28	65
RLE354A55	11,96	9,29	9707	19	63	8,9	5710	1000	1200	4x350	640	2,8	58	2340	585	460	5/8"SAE	35	82
RLE354B55	15,49	11,75	9181	18	94,6	13,35	7280	1000	1200	4x350	640	2,8	58	2340	585	460	5/8"SAE	35	86
RLE401B55	5,37	4,27	3269	18	32,3	4,56	3600	450	350	1x400	190	0,8	56	910	685	630	1/2"SAE	24	40
RLE401C55	6,29	4,84	3121	17	43,1	6,09	4500	450	350	1x400	190	0,8	56	910	685	630	1/2"SAE	24	45
RLE402B55	11,04	8,59	6579	20	66,4	9,37	7200	900	700	2x400	380	1,6	59	1510	685	630	5/8"SAE	35	82
RLE402C55	12,9	10,02	6291	19	88,5	12,49	9000	900	700	2x400	380	1,6	59	1510	685	630	5/8"SAE	35	90
RLE403B55	16,68	12,87	9888	21	100,4	14,17	10000	1250	1050	3x400	570	2,4	61	2110	685	630	22	42	114
RLE403C55	19,41	14,85	9459	20	133,9	18,9	12500	1250	1050	3x400	570	2,4	61	2110	685	630	22	42	125

Fin spacing 7 mm																				
BLE251A7	1,57	1,26	1619	14	7,5	1,33	1050	270	300	1x250	120	0,53	59	840	395	460	1/2"SAE	12	14	
BLE251B7	2,14	1,64	1529	13	11,3	2	1440	270	300	1x250	120	0,53	59	840	395	460	1/2"SAE	12	16	
BLE252A7	3,14	2,24	3238	16	15,1	2,67	2100	540	600	2x250	240	1,06	62	1340	395	460	1/2"SAE	22	22	
BLE252B7	4,34	3,36	3058	15	22,6	4	2880	540	600	2x250	240	1,06	62	1340	395	460	1/2"SAE	22	27	
BLE253A7	4,9	3,77	4857	17	22,6	4	3160	800	900	3x250	360	1,59	64	1840	395	460	1/2"SAE	22	33	
BLE253B7	6,26	4,47	4587	16	33,9	6,01	4340	800	900	3x250	360	1,59	64	1840	395	460	1/2"SAE	22	38	
BLE351A7	2,46	2,01	2455	15	12,6	2,22	1440	270	300	1x350	160	0,7	52	840	585	460	1/2"SAE	22	28	
BLE351B7	3,41	2,69	2338	14	18,8	3,34	1830	270	300	1x350	160	0,7	52	840	585	460	1/2"SAE	22	34	
BLE352A7	5,11	4,09	4910	17	25,1	4,45	2880	540	600	2x350	320	1,4	55	1340	585	460	1/2"SAE	24	38	
BLE352B7	6,9	5,25	4676	16	37,7	6,67	3660	540	600	2x350	320	1,4	55	1340	585	460	1/2"SAE	24	45	
BLE353A7	7,75	6,13	7365	18	37,7	6,67	4340	800	900	3x350	480	2,1	57	1840	585	460	1/2"SAE	28	54	
BLE353B7	10,4	8,1	7014	17	56,5	10,01	5520	800	900	3x350	480	2,1	57	1840	585	460	5/8"SAE	28	63	
BLE354A7	10,39	8,16	9819	19	50,2	8,9	5710	1000	1200	4x350	640	2,8	58	2340	585	460	5/8"SAE	35	80	
BLE354B7	13,88	10,64	9352	18	75,3	13,35	7280	1000	1200	4x350	640	2,8	58	2340	585	460	5/8"SAE	35	82	
BLE401B7	4,74	3,79	3321	18	25,8	4,56	3600	450	350	1x400	190	0,8	56	910	685	630	1/2"SAE	24	38	
BLE401C7	5,71	4,43	3184	17	34,3	6,09	4500	450	350	1x400	190	0,8	56	910	685	630	1/2"SAE	24	42	
BLE402B7	9,8	7,7	6680	20	52,9	9,37	7200	900	700	2x400	380	1,6	59	1510	685	630	5/8"SAE	35	76	
BLE402C7	11,7	9,17	6413	19	70,5	12,49	9000	900	700	2x400	380	1,6	59	1510	685	630	5/8"SAE	35	85	
BLE403B7	14,84	11,57	10038	21	80	14,17	10000	1250	1050	3x400	570	2,4	61	2110	685	630	22	42	108	
BLE403C7	17,69	13,65	9641	20	106,6	18,9	12500	1250	1050	3x400	570	2,4	61	2110	685	630	22	42	118	

* Nominal capacity according to ENV328 and Eurovent rules (refrigerant R404A, ΔT1 = T_{inair} - T_{ev}). Use external equalized thermostatic expansion valve.

Selection Chart

For an easy thermal selection, we suggest to use our program Palladio or the following diagrams valid for R404A / R507, DX evaporator, R.H. = 80 ÷ 90 % and ΔT_{suph} = 5 K:

AlfaCubic • GL • RL • BL D=250

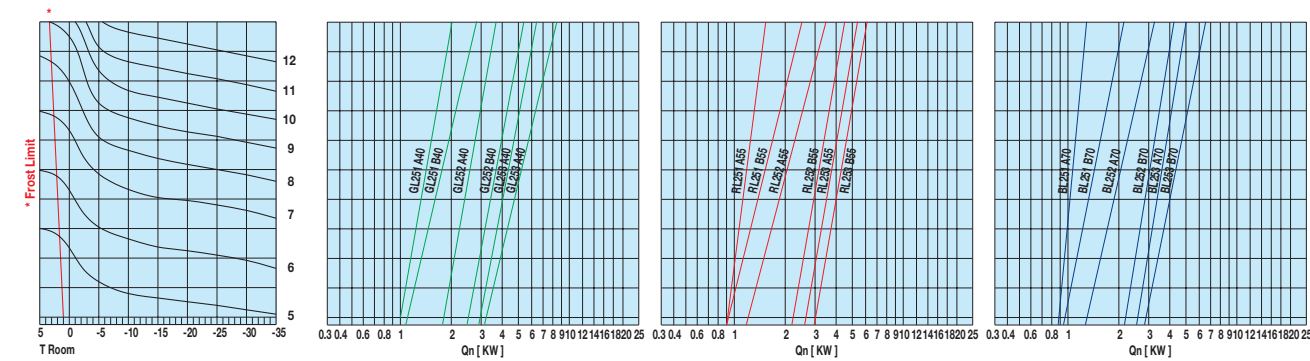

AlfaCubic • GL • RL • BL D=350

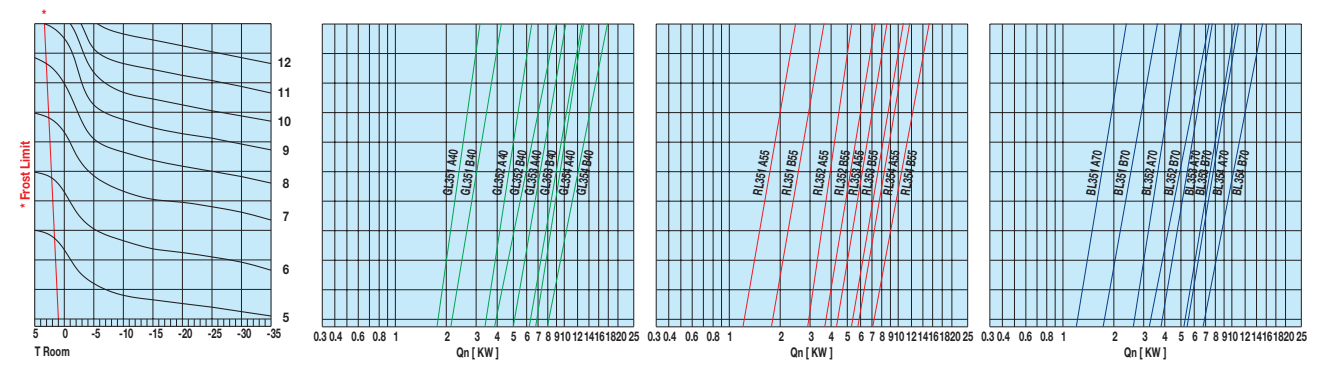

AlfaCubic • GL • RL • BL D=400

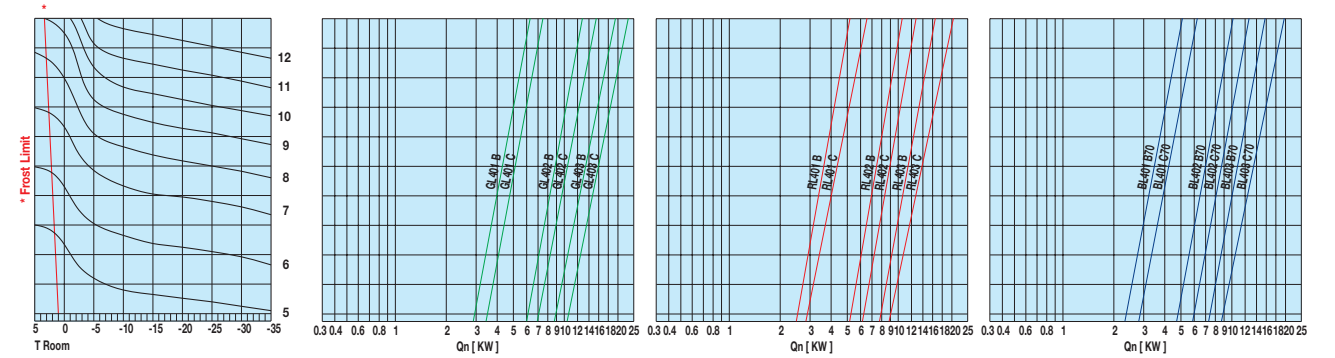

AlfaCubic • GL • RL • BL

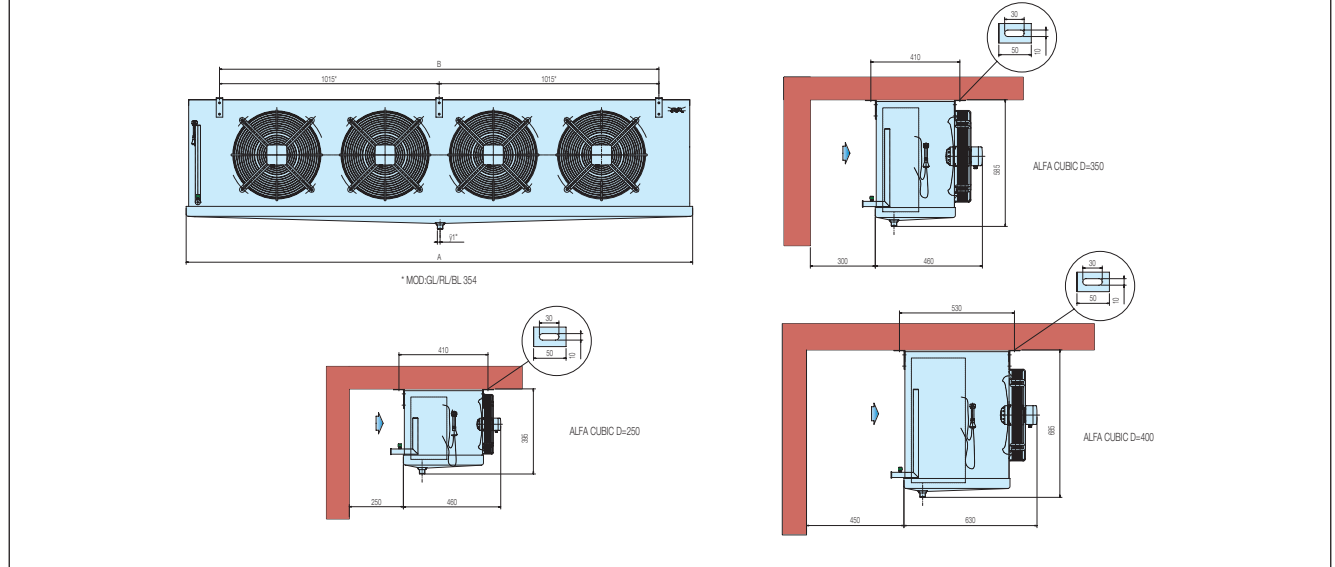

Ordering Code

Model (i)	GL • RL • BL Alfa Cubic
Application (ii)	E = Direct expansion evaporator • W = Brine unit cooler • A = Ammonia pump evaporator
Fans (iii)	Diameter and Number
Coil size (iv)	A • B • C
Fin spacing (v)	4 • 5,5 • 7
Defrost (vi)	A = Air • E = Electric • HG = Hot Gas • HG-E = Hot Gas + Electric • FRH = Fan ring heater
Fans motors (vii)	A = Single phase • T = Three phase

Example: RL E 352 B 55 E S
(i) (ii) (iii) (iv) (v) (vi) (vii)

Series	GL	RL	BL
Product	Fruits / Vegetables	Meat / fish	Frozen food
Room temperature	10 ÷ 0°C	0 ÷ -7°C	-18 ÷ -25°C
Fin spacing	4 mm	5,5 mm	7 mm



Top

TGL • TBL



Application

These units with double air flux, are designed for use in cold rooms mainly for fresh goods with volume from 10 to 150 m³. Units designed for an easy maintenance with immediate access to the inspection areas.

This series is available as: DX evaporator, NH₃ pump evaporator and Brine unit cooler.

Coil

Coil manufactured from corrugated aluminium fins and copper rippled tubes nominal diameter 12 mm for DX evaporator and smooth tubes nominal diameter 12 mm for Brine and 16 mm for NH₃ units.

Frame made from aluminium sheets

Casing

It's manufactured from anti-shock plastic materials, suitable for applications where a high degree of hygiene is required.

Fans

Single-phase motor 230V-50Hz, 4 poles, Protection class IP 54 according to DIN 40050. Low power consumption. Integrated thermal protection by thermo-contacts.

This provides reliable protection against thermal overload.

Defrost

As optional is available the electric defrost

Optional

- Drain-pipe flexible electrical heater
- Coil epoxy coating
- Cataphoresis treatment
- Stainless steel tubes
- Motors 3 Ph-400V-50Hz, 4 poles
- Motors 1 Ph-230V-50Hz, 6 poles
- Re-Heating coil

Top TGL

Model	Capacity SC2	Capacity SC3	Air Flow	Air Throw	Surface	Tube volume	Defrost **	Fan motors	Power consump.	Current consump.	Noise	Connections		Weight
	kW	kW										inlet	outlet	
	$\Delta T = 8K$ Tev = -8°C	$\Delta T = 7K$ Tev = -25°C	m ³ /h	m	m ²	dm ³	W	n° x Ømm	W	A	dB(A)	mm	mm	
TGL31	1,58	1,4	1420	7	11,4	2	950	1x300	90	0,4	48	1/2"SAE	16	23
TGL32	2,11	1,93	1320	6,5	15,3	2,3	950	1x300	90	0,4	48	1/2"SAE	16	26
TGL33	3,27	2,9	2840	10	22,9	3,1	1900	2x300	180	0,8	51	1/2"SAE	20	36
TGL34	4,16	3,56	2640	9	30,5	4,6	1900	2x300	180	0,8	51	1/2"SAE	20	41
TGL35	5,21	4,73	4780	13	35,3	4,8	2900	2x350	320	1,4	55	1/2"SAE	24	50
TGL36	6,95	6,19	4460	12	47	6,3	2900	2x350	320	1,4	55	1/2"SAE	24	58
TGL37	8,12	7,06	7160	16	52,9	6,7	4400	3x350	480	2,1	57	1/2"SAE	28	71
TGL38	10,32	9,23	6690	15	70,5	8,3	4400	3x350	480	2,1	57	5/8"SAE	28	83

Top TBL

Model	Capacity SC2	Capacity SC3	Air Flow	Air Throw	Surface	Tube volume	Defrost **	Fan motors	Power consump.	Current consump.	Noise	Connections		Weight
	kW	kW										inlet	outlet	
	$\Delta T = 8K$ Tev = -8°C	$\Delta T = 7K$ Tev = -25°C	m ³ /h	m	m ²	dm ³	W	n° x Ømm	W	A	dB(A)	mm	mm	
TBL61	1,2	0,97	1471	7,5	7,5	2	950	1x300	90	0,4	48	1/2"SAE	16	22
TBL62	1,91	1,57	1400	7	10	2,3	950	1x300	90	0,4	48	1/2"SAE	16	25
TBL63	2,5	2,02	2941	10,5	15,1	3,1	1900	2x300	180	0,8	51	1/2"SAE	20	34
TBL64	3,42	2,7	2800	9,5	20,1	4,6	1900	2x300	180	0,8	51	1/2"SAE	20	38
TBL65	4,54	3,73	4971	14	23,2	4,8	2900	2x350	320	1,4	55	1/2"SAE	24	47
TBL66	5,94	4,82	4692	13	30,9	6,3	2900	2x350	320	1,4	55	1/2"SAE	24	54
TBL67	6,55	5,25	7449	16,5	34,8	6,7	4400	3x350	480	2,1	57	1/2"SAE	28	67
TBL68	8,66	7,04	7038	15,5	46,4	8,3	4400	3x350	480	2,1	57	5/8"SAE	28	77

* Nominal capacity according to EN328 and Eurovent rules (refrigerant R404A, $\Delta T1 = T_{INair} - T_{ev}$)

** Defrost: E = Electric heaters in the coil and in drain pan. HG = Coil

hot gas and electric heater in drain pan. As option electric heater

RS = 70 W in drain-pipe. From models GL43, RL53, BL73, TGL32, TBL62 an expansion valve with external equalizer must be used.

Selection Chart

For an easy thermal selection, we suggest to use our program Palladio or the following diagrams valid for R404A / R507, DX evaporator, R.H. = 80 ÷ 90 % and $\Delta T_{suph} = 5 K$:

Top • TGL • TBL

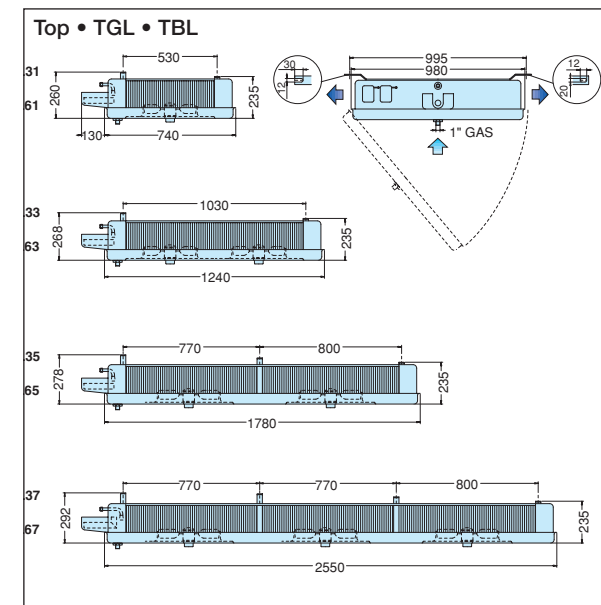
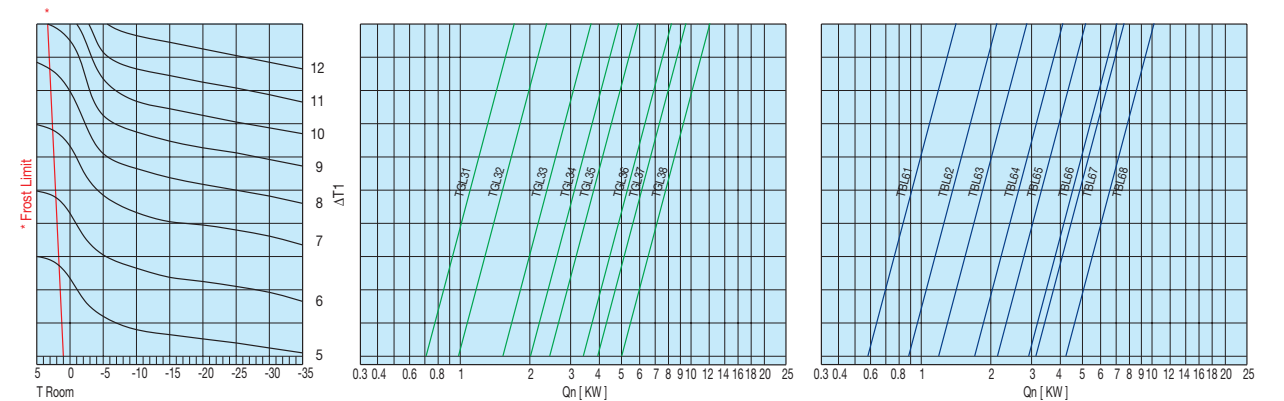

Series	TGL	TBL
Product	Fruits / Vegetables	Frozen food
Room temperature Tc	10 ÷ 0°C	-18 ÷ -25°C
Fin spacing	4,5 mm	7,0 mm

Ordering Code	
Model (I)	TGL • TBL Top unit cooler
Defrost (II)	A = Air • E = Electric • HG = Hot gas
Fan motors (III)	S = Single phase (1Ph) • T = Three phase 6P = 6 Poles
Casing (IV)	P = Plastic M = Metallic

Example: TGL31 A S P
(I) (II) (III) (IV)



Ceiling



BFG • BFB

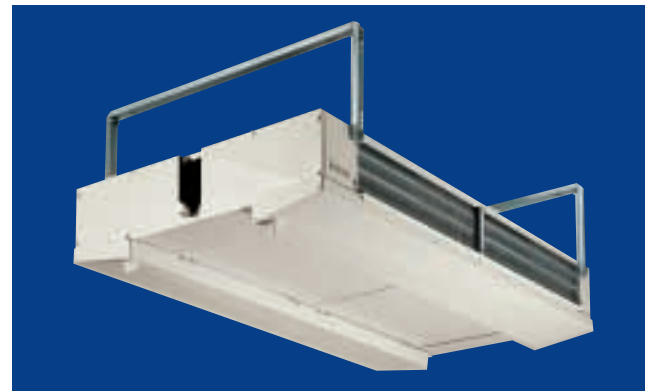

Ceiling



TFG

Application

Series with double air flux, designed for use in cold rooms for fresh and frozen goods with volume from 100 to 800 m³. Units designed for an easy maintenance with immediate access to the inspection areas.

This series is available as: DX evaporator, NH3 pump evaporator and Brine unit cooler.

Coil

Coil manufactured from corrugated aluminium fins and copper rippled tubes nominal diameter 12 mm for DX evaporator and smooth tubes nominal diameter 16 mm for Brine and NH3 units.

Casing

It's manufactured from pre-painted aluminium sheets RAL 9010, protected by plastic film, suitable for applications where a high degree of hygiene is required and also for sea environment.

Fans

Three-phase motor 400V-50Hz, with double fan speed (standard D connection with 1400 rpm and Y connection with 1240 rpm). Protection class IP 54 according to DIN 40050. Low power consumption. Integrated thermal protection by thermo contacts. This provides reliable protection against thermal overload

Defrost

As optional is available the electric defrost.

Optional

- Coil coating with three years warranty
- Cataphoresis treatment
- Stainless steel tubes
- Motors 1 Ph-230V-50Hz
- Re-Heating coil
- Motors cabling
- Insulated drip trays
- Casing in stainless steel

Application

Series with double air flux, designed for use mainly in working and packaging, where it's basic to have low noise level and low air velocity. Cold room volumes from 50 to 500 m³. Units designed for an easy maintenance with immediate access to the inspection areas. This series is available as: DX evaporator, NH3 pump evaporator and Brine unit cooler. This series is available as: DX evaporator, NH3 pump evaporator and Brine unit cooler.

This series is available as: DX evaporator, NH3 pump evaporator and Brine unit cooler.

Coil

Coil manufactured from corrugated aluminium fins and copper rippled tubes nominal diameter 12 mm for DX evaporator and smooth tubes nominal diameter 16 mm for Brine and NH3 units.

Casing

It's manufactured from pre-painted aluminium sheets RAL 9010, protected by plastic film, suitable for applications where a high degree of hygiene is required and also for sea environment.

Fans

Three-phase motor 400V-50Hz, with double fan speed (standard Y connection with 1240 rpm and D connection with 1400 rpm). Protection class IP 54 according to DIN 40050. Low power consumption. Integrated thermal protection by thermo contacts. This provides reliable protection against thermal overload.

Defrost

As optional is available the electric defrost.

Optional

- Coil coating with three years warranty
- Cataphoresis treatment
- Stainless steel tubes
- Motors 1 Ph-230V-50Hz
- Re-Heating coil
- Motors cabling
- Insulated drip trays
- Casing in stainless steel

Ceiling • BFG • BFB

Model	Capacity * SC2	Capacity * SC3	Air Flow	Air Throw	Surface	Tube volume	Defrost	Fan motors	Power consumption	Current consumption	Noise	Dimensions				Connections		Weight
	kW	kW										m ³ /h	m	m ²	dm ³	W	n° x Ømm	
	ΔT= 8K Tev= -8°C	ΔT= 7K Tev= -25°C					E				(5m)	A	B	C	D	inlet	outlet	
BFGE402B4	9,98	7,7	7400	2x18	67,5	7,1	6400	2x400	400	1,12	61	1975	1610	-	-	22	35	90
BFGE402C4	12,84	10,05	7110	2x17	101,2	10,6	8800	2x400	400	1,12	61	1975	1610	-	-	22	35	97
BFGE403B4	15,06	11,72	11100	2x22	101,2	10,6	9200	3x400	600	1,68	63	2765	2400	-	-	22	42	134
BFGE403C4	19,28	15,36	10660	2x21	151,9	15,9	12600	3x400	600	1,68	63	2765	2400	-	-	28	42	140
BFGE404B4	20,01	15,5	14800	2x26	135	14,1	12000	4x400	800	2,24	64	3555	3190	1580	1610	28	42	156
BFGE404C4	25,75	20,26	14210	2x25	202,5	21,1	16400	4x400	800	2,24	64	3555	3190	1580	1640	35	54	172
BFGE405B4	25,05	19,43	18500	2x29	168,7	17,6	14800	5x400	1000	2,8	65	4345	3980	1580	1620	35	54	186
BFGE405C4	32,3	25,26	17760	2x28	253,1	26,4	20200	5x400	1000	2,8	65	4345	3980	1580	1620	35	54	236

BFBE402B7	7,18	5,66	7550	2x20	39,7	7,1	6400	2x400	400	1,12	61	1975	1610	-	-	22	35	82
BFBE402C7	9,68	7,19	7342	2x19	59,5	10,6	8800	2x400	400	1,12	61	1975	1610	-	-	22	35	90
BFBE403B7	10,84	8,6	11325	2x23	59,5	10,6	9200	3x400	600	1,68	63	2765	2400	-	-	22	42	130
BFBE403C7	14,56	10,88	11013	2x22	89,2	15,9	12600	3x400	600	1,68	63	2765	2400	-	-	22	42	134
BFBE404B7	14,56	11,07	15085	2x28	79,3	14,1	12000	4x400	800	2,24	64	3555	3190	1580	1610	22	42	148
BFBE404C7	19,56	14,69	14684	2x27	119	21,1	16400	4x400	800	2,24	64	3555	3190	1580	1640	28	54	167
BFBE405B7	18,17	13,89	18857	2x31	99,2	17,6	14800	5x400	1000	2,8	65	4345	3980	1580	1620	28	54	170
BFBE405C7	24,36	18,25	18337	2x30	148,7	26,4	20200	5x400	1000	2,8	65	4345	3980	1580	1620	35	54	210

Ceiling TFG

Model	Capacity * SC2	Capacity * SC3	Air Flow	Air Throw	Surface	Tube volume	Defrost	Fan motors	Power consumption	Current consumption	Noise	Dimensions				Connections		Weight
	kW	kW										m ³ /h	m	m ²	dm ³	W	n° x Ømm	
	ΔT= 8K Tev= -8°C	ΔT= 7K Tev= -25°C					E				(5m)	A	B	C	D	inlet	outlet	
TFGE401A4	3,68	2,93	3130	2x10	25,3	2,7	2000	1x400	137	0,23	54	1120	820	-	-	5/8"SAE	28	53
TFGE401B4	4,52	3,48	3070	2x9	33,7	3,5	3200	1x400	137	0,23	54	1120	820	-	-	5/8"SAE	28	59
TFGE402A4	7,4	5,94	6250	2x14	50,6	5,3	4000	2x400	274	0,46	57	1910	1610	-	-	5/8"SAE	35	74
TFGE402B4	9,11	7,07	6130	2x13	67,5	7,1	6400	2x400	274	0,46	57	1910	1610	-	-	5/8"SAE	35	80
TFGE403A4	11,17	8,45	9380	2x17	75,9	7,9	5800	3x400	411	0,69	59	2700	2400	-	-	22	42	114
TFGE403B4	13,76	10,76	9200	2x16	101,2	10,6	9200	3x400	411	0,69	59	2700	2400	-	-	28	42	130
TFGE404B4	18,29	14,25	12260	2x18	135	14,1	12000	4x400	548	0,92	60	3490	3190	1580	1610	28	48	135
TFGE405B4	22,88	17,84	15330	2x20	168,7	17,6	14800	5x400	685	1,15	61	4280	3190	1580	1610	35	48	170

* Nominal capacity according to ENV328 and Eurovent rules (refrigerant R404A, ΔT1 = T_{inair} - T_{ev}).

Use external equalized thermostatic expansion valve.

Ceiling • BFG • BFB

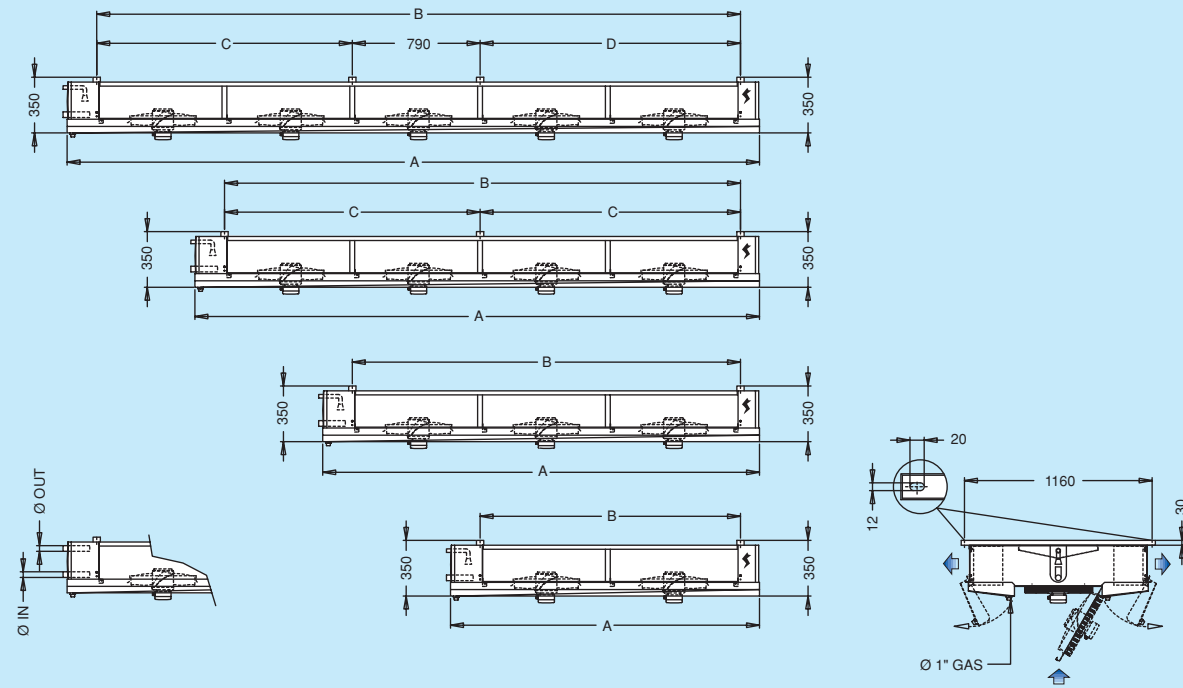

Selection Chart

For an easy thermal selection, we suggest to use our program Palladio or the following diagrams valid for R404A / R507, DX evaporator, R.H. = 80 ÷ 90 % and $\Delta T_{suph} = 5$ K:

Ceiling • BFG • BFB

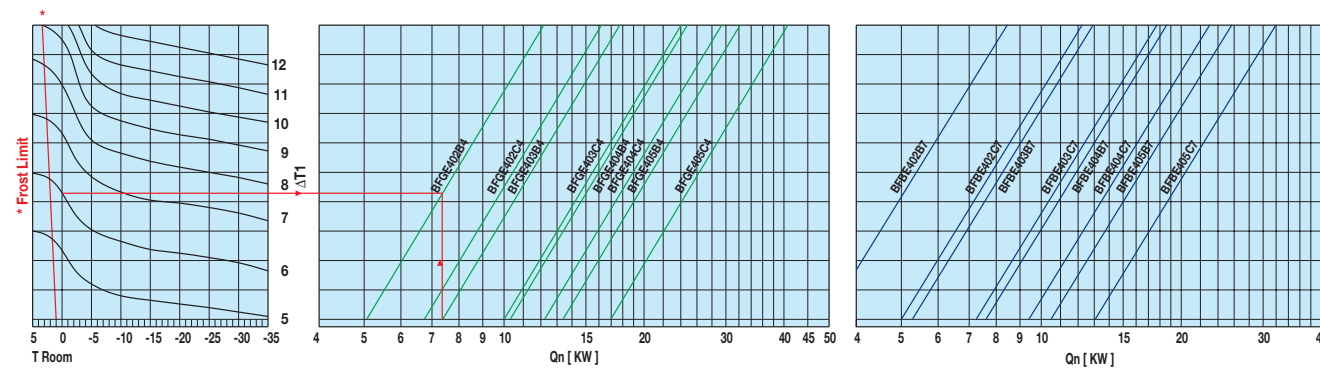

Series	BFG	BFB
Product	Fruits / Vegetables	Frozen goods
Room temperature Tc	10 ÷ 0°C	-18 ÷ -25°C
Fin spacing	4 mm	7 mm

Ordering Code	
Model (I)	BFG • BFB Bottom Fan Ceiling
Application (II)	E = Direct expansion evaporator • W = Brine unit cooler • A = Ammonia pump evaporator
Fans (III)	Diameter and Number
Coil size (IV)	B • C
Fin spacing (V)	4 • 7
Defrost (VI)	A = Air • E = Electric
Fans motors (VII)	A = Single phase • T = Three phase

Example: BFG E 403 B4 E T
(I) (II) (III) (IV) (V) (VI) (VII)

Ceiling TFG

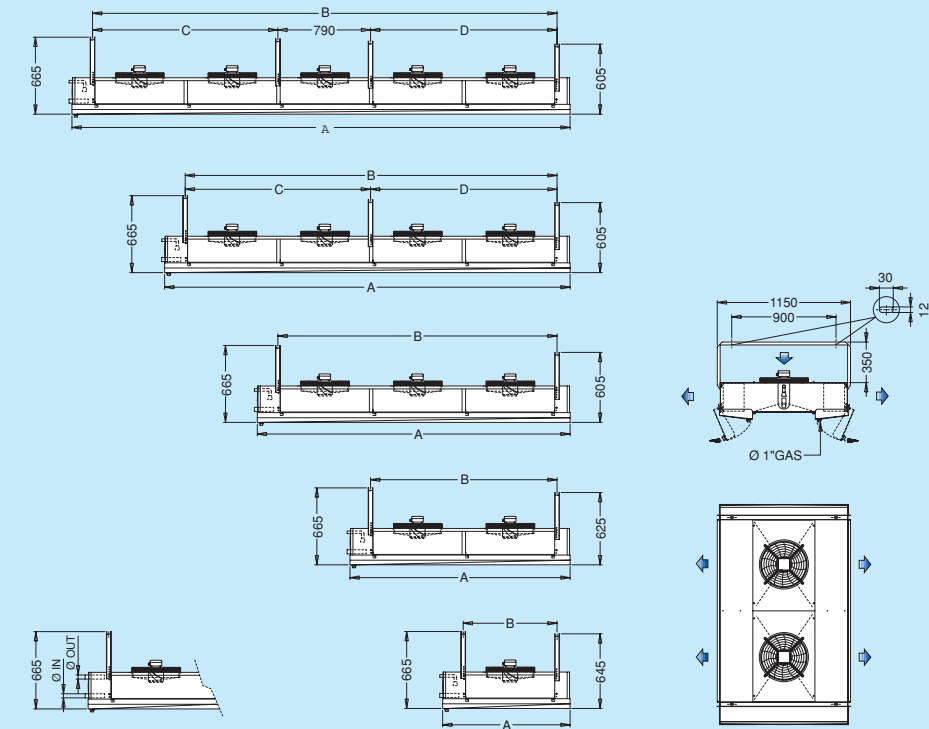

Selection Chart

For an easy thermal selection, we suggest to use our program Palladio or the following diagrams valid for R404A / R507, DX evaporator, R.H. = 80 ÷ 90 % and $\Delta T_{suph} = 5$ K:

Ceiling TFG

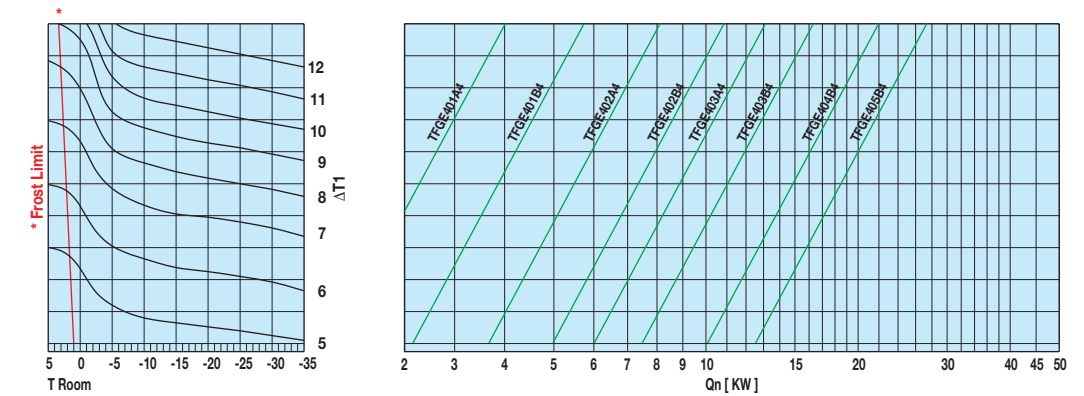

Series	TFG
Product	Fruits / Vegetables
Room temperature Tc	12 ÷ 0°C
Fin spacing	4 mm

Ordering Code	
Model (I)	TFG Top Fan Ceiling
Application (II)	E = Direct expansion evaporator • W = Brine unit cooler • A = Ammonia pump evaporator
Fans (III)	Diameter and Number
Coil size (IV)	A • B
Fin spacing (V)	4
Defrost (VI)	A = Air • E = Electric
Fans motors (VII)	A = Single phase • T = Three phase

Example: TFG E 403 B4 A T
(I) (II) (III) (IV) (V) (VI) (VII)



Ceiling Big Top



ITR • ITB

Application

Series with double air flux, designed for use in cold rooms for fresh and frozen goods with volume from 300 to 2000 m³. Units designed for an easy maintenance with immediate access to the inspection areas. This series is available as: DX evaporator, NH3 pump evaporator and Brine unit cooler.

Coil

Coil manufactured from corrugated aluminium fins and copper rippled tubes nominal diameter 12 mm for DX evaporator and smooth tubes nominal diameter 16 mm for Brine and NH3 units.

Casing

It's manufactured from pre-painted aluminium sheets RAL 9010, protected by plastic film, suitable for applications where a high degree of hygiene is required and also for sea environment.

Fans

Three-phase motor 400V-50Hz, double fan speed (standard D connection with 1300 rpm and Y connection with 970 rpm). Protection class IP 54 according to DIN 40050. Low power consumption. Integrated thermal protection by thermo contacts. This provides reliable protection against thermal overload

Defrost

As optional are available the following defrost: electric and water.

Optional

- Coil coating with three years warranty.
- Cataphoresis treatment
- Stainless steel tubes
- Motors cabling
- Insulated drip trays
- Casing in stainless steel

Ceiling Big Top • ITR • ITB

Use the expansion valve with external equalizer.

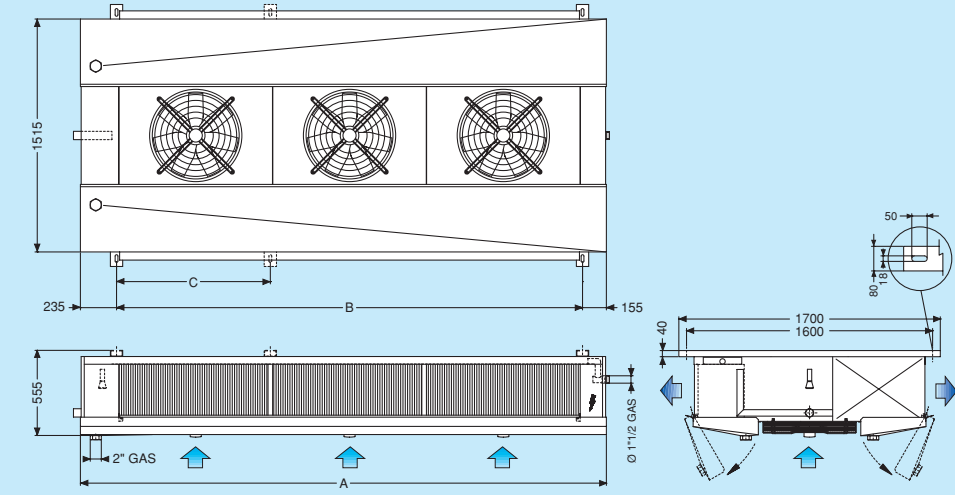

Selection Chart

For an easy thermal selection, we suggest to use our program Palladio or the following diagrams valid for R404A / R507, DX evaporator, R.H. = 80 ÷ 90 % and ΔTsuph = 5 K:

Ceiling Big Top • ITR • ITB

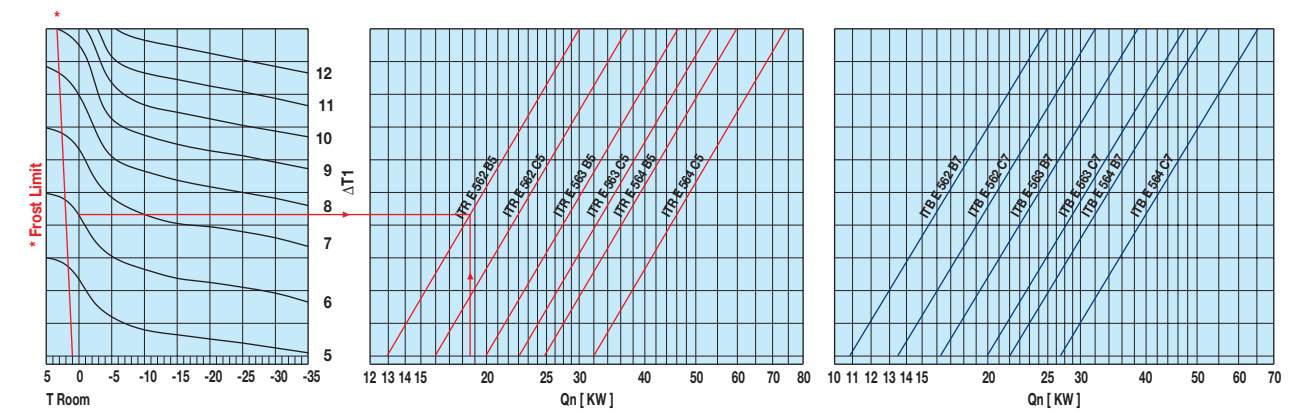

Big Top

Model	Capacity * SC2	Capacity * SC3	Air Flow	Air Throw	Surface	Tube volume	Defrost			Fan motors	Power consump.	Current consump.	Noise	Dimensions			Connections	Weight		
	kW ΔT= 8K Tev= -8°C	kW ΔT= 7K Tev= -25°C	m ² /h	m	m ²	dm ³	E	HG+E	W	n° x Ømm	W	A	dB(A)	mm	mm	mm	mm		mm	kg
ITRE562B5	26,05	19,97	20770	2x22	144,9	18,7	14,4	1,8	5120	10	2x560	2100	3,84	77	2420	2030	-	28	42	240
ITRE562C5	30,96	23,53	19660	2x21	193,2	24,9	17,6	1,8	6400	15	2x560	2100	3,84	77	2420	2030	-	35	42	260
ITRE563B5	38,92	29,39	31160	2x21	217,4	28,1	22,2	3	7680	15	3x560	3150	5,76	79	3420	3030	-	35	54	360
ITRE563C5	46,58	35,5	29490	2x21	289,9	37,4	27	3	9600	20	3x560	3150	5,76	79	3420	3030	-	35	54	390
ITRE564B5	52,25	40,2	41580	2x22	289,9	37,4	27,8	3,7	10240	20	4x560	4200	7,68	80	4420	4030	2000	35	54	480
ITRE564C5	62,61	48,16	39320	2x21	386,5	49,9	34,7	3,7	12840	25	4x560	4200	7,68	80	4420	4030	2000	35	60	520

ITBE562B7	21,82	16,87	21400	2x24	105,4	18,7	14,4	1,8	5120	10	2x560	2100	3,84	77	2420	2030	-	28	42	230
ITBE562C7	26,69	20,45	20410	2x23	140,6	24,9	17,6	1,8	6400	15	2x560	2100	3,84	77	2420	2030	-	35	42	248
ITBE563B7	32,77	25,03	32090	2x24	158,2	28,1	22,2	3	7680	15	3x560	3150	5,76	79	3420	3030	-	35	54	345
ITBE563C7	40,08	30,8	30620	2x23	210,9	37,4	27	3	9600	20	3x560	3150	5,76	79	3420	3030	-	35	54	372
ITBE564B7	44,01	33,78	42790	2x24	210,9	37,4	27,8	3,7	10240	20	4x560	4200	7,68	80	4420	4030	2000	35	54	460
ITBE564C7	53,39	40,44	40820	2x23	281,2	49,9	34,7	3,7	12840	25	4x560	4200	7,68	80	4420	4030	2000	35	60	496

* Nominal capacity according to ENV328 and Eurovent rules (refrigerant R404A, ΔT1 = T_{inair} - T_{ev}). Use external equalized thermostatic expansion valve.

Ordering Code	
Model (I)	ITR • ITB Big Top unit cooler
Application (II)	E = Direct expansion evaporator • W = Brine unit cooler • A = Ammonia pump evaporator
Fans (III)	Diameter and Number
Coil size (IV)	B • C
Fin spacing (V)	5 • 7
Defrost (VI)	A = Air • E = Electric • W = Water

Example: ITR E 563 B5 E
(I) (II) (III) (IV) (V) (VI)



- High performance
- Low refrigerant charge
- Suitable for every application

- Several options available
- Modular concept
- Easy maintenance

• DX • BRINE



Application

Series designed for use in cold rooms for fresh and frozen goods with volume from 200 to 5000 m³. Range with capacities from 6 to 210 kW and suitable for applications within temperature range from -40 to +30°C. This series is available as: DX evaporator and Brine unit cooler. The combination of several coil sizes, 4 different fan diameters and many fin spacing, offer a wide range of solutions to our clients (150 standard models as DX unit coolers, 168 standard models as Brine unit coolers, 240 standard models as NH₃ unit coolers). Thanks to a wide range of options and the possibility to have some customizations, Alfa Laval can fulfill every requirement.

Frame and Casing

Aluminum casing, protected by plastic film, suitable for applications where a high degree of hygiene is required. The galvanized steel frame combined with the aluminum casing, is the best solution concerning sturdiness and acceptable weight of the unit. The frame has been design in order to ensure an easy installation and maintenance. Drip tray provided of: double metal sheet for a good thermal insulation, all corners TIG welded for excellent sealing, hinges that assure a easy maintenance. The supports have two different mountings (flush mounted or space). Structural parts are fastened with stainless steel bolts and screws. Structure with excellent stability, to avoid vibrations also in heavy installations.

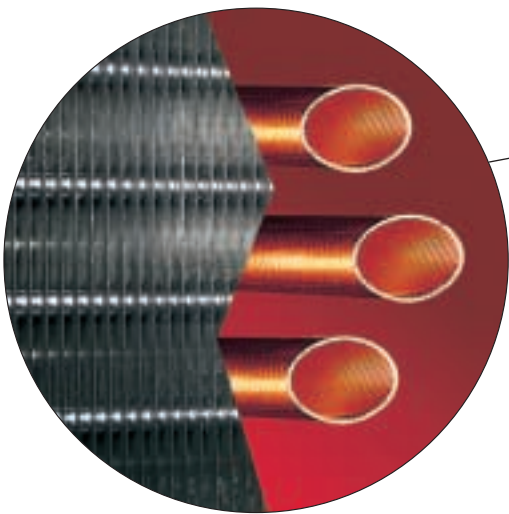

Coil

Innovative heat exchanger designed in order to offer the best performance for cooling and defrost and a minimized refrigerant charge. The particular fins corrugation provides high external surface, high external heat transfer factor and quick coil water drainage for minimizing the defrost time. The rippled tubes are much more efficient than tubes with a conventional smoothwalled design, besides a particular coil design for DX version ensures excellent oil entrainment to the compressor in every application. Coil manufactured from aluminum fins and copper tubes nominal diameter 12 mm for DX evaporator and smooth tubes nominal diameter 16 mm for Brine and NH₃ units.

Fans

High efficiency fans with low power consumption are used. Four different fan diameter available: 400 and 500 mm with three-phase motors (4/4 poles) 400V-50/60Hz, 560 and 630 mm with three-phase motors (4 poles) 230/400V-50/60Hz. The motors are with external rotor, constructed in accordance with VDE 0530/12.84. Protection class IP 54 according to DIN 40050. Integrated thermal protection by thermo contacts. This provides reliable protection against thermal overload. Fan diameter 630 mm with large bell mouth that optimizes the fan efficiency and ensures a lower noise level than a traditional short bell mouth.



Model	Capacity* SC2	Capacity* SC3	Air Flow	Air throw	Surface	Tube volume	Defrost*			Fan motor	Power consumption	Current consumption	Noise	Dimensions (see page 30)			Connections		Weight	
	kW	kW	m³/h	m	m²	dm³	E	HG+E	W	n° x Ømm	W	A	dB(A)	mm	mm	mm	mm	mm	kg	
Fin spacing 4,5 mm	ΔT1= 8K, Tev= -8°C	ΔT1= 7K Tev= -25°C					kW	kW	l/h	kPa			(5m)	A	B	C	inlet	outlet		
INGE402C45	12,5	9,5	6740	18	89,3	11	9	1,8	2300	10	2x400	520	1	59	1710	-	1200	16	28	95
INGE403B45	16,4	12,4	10880	19	101,3	12	10	2,5	2600	10	3x400	780	1,5	61	2310	-	1800	16	35	120
INGE403C45	18,9	14,2	10150	19	135,1	16	12,5	2,5	3400	15	3x400	780	1,5	61	2310	-	1800	16	35	133
INGE404B45	22,1	16,8	14530	20	135,6	16	14	3,5	3400	15	4x400	1040	2	62	2910	-	2400	22	42	154
INGE404C45	25,4	19,3	13540	20	180,9	22	17,5	3,5	4600	20	4x400	1040	2	62	2910	-	2400	22	42	173
INGE405B45	27,6	20,9	18180	21	170	20	17,6	4,4	4300	20	5x400	1300	2,5	63	3510	-	3000	22	42	192
INGE405C45	31,9	24,3	16960	21	226,6	27	22	4,4	5800	20	5x400	1300	2,5	63	3510	-	3000	22	54	213

Fin spacing 6 mm																				
INRE402C6	11,3	8,7	6960	18	67,9	11	9	1,8	2300	10	2x400	520	1	59	1710	-	1200	16	28	90
INRE403B6	14,4	11,1	11190	19	77,1	12	10	2,5	2600	10	3x400	780	1,5	61	2310	-	1800	16	35	114
INRE403C6	17,1	13	10470	19	102,8	16	12,5	2,5	3400	15	3x400	780	1,5	61	2310	-	1800	16	35	125
INRE404B6	19,4	15	14940	20	103,2	16	14	3,4	3400	15	4x400	1040	2	62	2910	-	2400	22	42	146
INRE404C6	22,9	17,6	13990	20	137,6	22	17,5	3,4	4600	20	4x400	1040	2	62	2910	-	2400	22	42	162
INRE405B6	24,2	18,6	18680	21	129,4	20	17,6	4,4	4300	20	5x400	1300	2,5	63	3510	-	3000	22	42	182
INRE405C6	28,8	22,2	17500	21	172,5	27	22	4,4	5800	20	5x400	1300	2,5	63	3510	-	3000	22	54	199

Fin spacing 8,5 mm																				
INBE402C85	9,9	7,7	7280	20	49,1	11	9	1,8	2300	10	2x400	520	1	59	1710	-	1200	16	35	85
INBE403B85	12,4	9,6	11590	21	55,7	12	10	2,5	2600	10	3x400	780	1,5	61	2310	-	1800	16	42	108
INBE403C85	15	11,5	10950	21	74,2	16	12,5	2,5	3400	15	3x400	780	1,5	61	2310	-	1800	16	42	118
INBE404B85	16,6	13	15490	22	74,6	16	14	3,4	3400	15	4x400	1040	2	62	2910	-	2400	22	42	139
INBE404C85	20,1	15,6	14610	22	99,4	22	17,5	3,4	4600	20	4x400	1040	2	62	2910	-	2400	22	42	153
INBE405B85	20,8	16,1	19370	23	93,4	20	17,6	4,4	4300	20	5x400	1300	2,5	63	3510	-	3000	22	42	172
INBE405C85	25,3	19,6	18280	23	124,6	27	22	4,4	5800	20	5x400	1300	2,5	63	3510	-	3000	22	54	180

Fin spacing 10 mm																				
INBE402C10	9,2	7,1	7410	20	42,3	11	9	1,8	2300	10	2x400	520	1	59	1710	-	1200	16	35	85
INBE403B10	11,3	8,9	11760	21	48	12	10	2,5	2600	10	3x400	780	1,5	61	2310	-	1800	16	42	108
INBE403C10	13,9	10,7	11140	21	64	16	12,5	2,5	3400	15	3x400	780	1,5	61	2310	-	1800	16	42	118
INBE404B10	15,2	11,9	15710	22	64,3	16	14	3,4	3400	15	4x400	1040	2	62	2910	-	2400	22	42	139
INBE404C10	18,5	14,5	14870	22	85,7	22	17,5	3,4	4600	20	4x400	1040	2	62	2910	-	2400	22	42	153
INBE405B10	19	14,8	19650	23	80,5	20	17,6	4,4	4300	20	5x400	1300	2,5	63	3510	-	3000	22	42	172
INBE405C10	23,3	18,2	18600	23	107,4	27	22	4,4	5800	20	5x400	1300	2,5	63	3510	-	3000	22	54	180

Fin spacing 12 mm																				
INBE402C12	8,4	6,6	7540	20	35,9	11	9	1,8	2300	10	2x400	520	1	59	1710	-	1200	16	35	85
INBE403B12	10,2	8	11930	21	40,7	12	10	2,5	2600	10	3x400	780	1,5	61	2310	-	1800	16	42	108
INBE403C12	12,7	9,9	11340	21	54,3	16	12,5	2,5	3400	15	3x400	780	1,5	61	2310	-	1800	16	42	118
INBE404B12	13,7	10,8	15940	22	54,6	16	14	3,4	3400	15	4x400	1040	2	62	2910	-	2400	22	42	139
INBE404C12	16,9	13,3	15140	22	72,7	22	17,5	3,4	4600	20	4x400	1040	2	62	2910	-	2400	22	42	153
INBE405B12	17,1	13,5	19940	23	68,4	20	17,6	4,4	4300	20	5x400	1300	2,5	63	3510	-	3000	22	42	172
INBE405C12	21,3	16,7	18940	23	91,2	27	22	4,4	5800	20	5x400	1300	2,5	63	3510	-	3000	22	54	180

* Nominal capacity according to EN328 and Eurovent rules (refrigerant R404A, ΔT1 = T_{INair} - T_{ev})
Use external equalized thermostatic expansion valve.

Model	Capacity* SC2	Capacity* SC3	Air Flow	Air Throw	Surface	Tube volume	Defrost*			Fan motor	Power consumption	Current consumption	Noise	Dimensions (see page 30)			Connections		Weight	
	kW	kW	m³/h	m	m²	dm³	E	HG+E	W	n° x Ømm	W	A	dB(A)	mm	mm	mm	mm	mm	kg	
Fin spacing 4,5 mm	ΔT1= 8K, Tev= -8°C	ΔT1= 7K, Tev= -25°C					kW	kW	l/h	kPa			(5m)	A	B	C	inlet	outlet		
INGE502A45	16,8	12,2	15250	31	95,6	12	9,6	3,2	2400	10	2x500	1580	2,7	66	2210	-	1700	16	35	108
INGE502B45	22,6	17	14610	30	143,4	18	12,8	3,2	3600	15	2x500	1580	2,7	66	2210	-	1700	22	35	127
INGE502C45	26,3	19,8	13990	29	191,2	23	16	3,2	4900	20	2x500	1580	2,7	66	2210	-	1700	22	42	145
INGE503B45	33,7	24,9	21940	31	216,3	26	22,4	5,6	5500	20	3x500	2370	4,05	68	3060	-	2550	22	42	178
INGE503C45	39,8	30	21020	30	288,5	35	28	5,6	7300	25	3x500	2370	4,05	68	3060	-	2550	28	42	195
INGE504B45	45,2	33,5	29270	32	289,3	35	28,6	5,2	7400	25	4x500	3160	5,4	69	3910	3400	1700	28	54	225
INGE504C45	53,2	40,2	28040	31	385,8	46	31,2	5,2	9800	30	4x500	3160	5,4	69	3910	3400	1700	28	54	273
INGE505B45	56,2	41,4	36600	33	362,3	43	34	6,8	9200	30	5x500	3950	6,75	70	4760	4250	1700	28	54	268
INGE505C45	65,9	48,8	35110	32	483,1	57	40,8	6,8	12300	35	5x500	3950	6,75	70	4760	4250	1700	28	60	315

Fin spacing 6 mm																				
INRE502A6	14,5	10,8	15390	31	72,7	12	9,6	3,2	2400	10	2x500	1580	2,7	66	2210	-	1700	16	35	102
INRE502B6	19,8	15,1	14840	30	109,1	18	12,8	3,2	3600	15	2x500	1580	2,7	66	2210	-	1700	22	35	119
INRE502C6	23,7	18	14280	29	145,5	23	16	3,2	4900	20	2x500	1580	2,7	66	2210	-	1700	22	42	134
INRE503B6	29,6	22,4	22280	31	164,6	26	22,4	5,6	5500	20	3x500	2370	4,05	68	3060	-	2550	22	42	165
INRE503C6	35,7	27,3	21470	30	219,5	35	28	5,6	7300	25	3x500	2370	4,05	68	3060	-	2550	28	42	178
INRE504B6	39,6	30,1	29720	32	220,2	35	28,6	5,2	7400	25	4x500	3160	5,4	69	3910	3400	1700	28	54	207
INRE504C6	47,7	36,6	28640	31	293,5	46	31,2	5,2	9800	30	4x500	3160	5,4	69	3910	3400	1700	28	54	250
INRE505B6	49,4	37,2	37160	33	275,7	43	34	6,8	9200	30	5x500	3950	6,75	70	4760	4250	1700	28	54	246
INRE505C6	59,3	44,6	35810	32	367,6	57	40,8	6,8	12300	35	5x500	3950	6,75	70	4760	4250	1700	28	60	286

Fin spacing 8,5 mm																			
-----------------------	--	--	--	--	--	--	--	--	--	--	--	--	--	--	--	--	--	--	--

Model	Capacity* SC2	Capacity* SC3	Air Flow	Air Throw	Surface	Tube volume	Defrost*				Fan motors	Power consumption	Current consumption	Noise	Dimensions (see page 30)			Connections		Weight
	kW	kW	m³/h	m	m²		E	HG+E	W	n° x Ømm	W	A	dB(A)	mm	mm	mm	mm	mm	mm	
Fin spacing 4,5 mm	ΔT1= 8K, Tev= -8°C	ΔT1= 7K, Tev= -25°C				kW	kW	l/h	kPa			(5m)	A	B	C	inlet	outlet			
INGE562B45	34,4	25,7	21840	39	225,5	27	18,8	3,2	5700	20	2x560	2000	3,6	77	2510	-	2000	22	42	230
INGE562C45	40,2	30,5	20760	38	300,7	36	22	3,2	7600	25	2x560	2000	3,6	77	2510	-	2000	28	54	259
INGE562E45	43,7	32,9	19760	37	375,8	46	25,1	3,2	9600	30	2x560	2000	3,6	77	2510	-	2000	28	54	289
INGE563B45	52,4	39,5	32790	40	340	41	28,8	4,8	8600	25	3x560	3000	5,4	79	3510	-	3000	28	54	336
INGE563C45	61	46,7	31190	39	453,3	54	36,6	4,8	11500	30	3x560	3000	5,4	79	3510	-	3000	28	60	367
INGE563E45	66,1	50,1	29690	38	566,6	68	38,4	4,8	14400	35	3x560	3000	5,4	79	3510	-	3000	35	76	425
INGE564C45	81	61,7	41620	40	605,9	72	43,4	6,2	15400	35	4x560	4000	7,2	80	4510	4000	2000	2x28	2x54	482
INGE565C45	100,8	75	52050	41	758,5	90	53,2	7,6	19300	38	5x560	5000	9	81	5510	5000	2000	2x28	2x54	597

Fin spacing 6 mm																				
INRE562B6	30,3	23	22220	39	171,6	27	18,8	3,2	5700	20	2x560	2000	3,6	77	2510	-	2000	22	42	216
INRE562C6	36,2	27,8	21260	38	228,8	36	22	3,2	7600	25	2x560	2000	3,6	77	2510	-	2000	28	54	241
INRE562E6	40,3	30,7	20350	37	286	46	25,1	3,2	9600	30	2x560	2000	3,6	77	2510	-	2000	28	54	266
INRE563B6	45,9	35,2	33360	40	258,7	41	28,8	4,8	8600	25	3x560	3000	5,4	79	3510	-	3000	28	54	316
INRE563C6	54,9	42,5	31920	39	344,9	54	33,6	4,8	11500	30	3x560	3000	5,4	79	3510	-	3000	28	60	340
INRE563E6	60,9	46,7	30580	38	431,2	68	38,4	4,8	14400	35	3x560	3000	5,4	79	3510	-	3000	35	76	392
INRE564C6	73	56,2	42590	40	461,1	72	43,4	6,2	15400	35	4x560	4000	7,2	80	4510	4000	2000	2x28	2x54	445
INRE565C6	91	68,9	53260	41	577,2	90	53,2	7,6	19300	38	5x560	5000	9	81	5510	5000	2000	2x28	2x54	553

Fin spacing 8,5 mm																				
INBE562B85	26	20	22720	41	123,9	27	18,8	3,2	5700	20	2x560	2000	3,6	77	2510	-	2000	22	54	204
INBE562C85	31,6	24,5	21910	40	165,3	36	22	3,2	7600	25	2x560	2000	3,6	77	2510	-	2000	28	54	225
INBE562E85	36,1	27,8	21110	39	206,6	46	25,1	3,2	9600	30	2x560	2000	3,6	77	2510	-	2000	28	54	246
INBE563B85	39,3	30,5	34100	42	186,9	41	28,8	4,8	8600	25	3x560	3000	5,4	79	3510	-	3000	28	54	298
INBE563C85	47,8	37,4	32890	41	249,1	54	33,6	4,8	11500	30	3x560	3000	5,4	79	3510	-	3000	28	76	316
INBE563E85	54,5	42,1	31700	40	311,4	68	38,4	6,2	14400	35	3x560	3000	5,4	79	3510	-	3000	35	76	363
INBE564C85	63,7	49,5	43880	42	333	72	43,4	7,6	15400	35	4x560	4000	7,2	80	4510	4000	2000	2x28	2x54	414
INBE565C85	80,1	61,2	54870	43	416,9	90	53,2	7,6	19300	38	5x560	5000	9	81	5510	5000	2000	2x28	2x54	513

Fin spacing 10 mm																				
INBE562B10	23,8	18,4	22900	41	106,8	27	18,8	3,2	5700	20	2x560	2000	3,6	77	2510	-	2000	22	54	204
INBE562C10	29,2	22,8	22150	40	142,5	36	22	3,2	7600	25	2x560	2000	3,6	77	2510	-	2000	28	54	225
INBE562E10	33,6	26,1	21400	39	178,1	46	25,1	3,2	9600	30	2x560	2000	3,6	77	2510	-	2000	28	54	246
INBE563B10	35,9	28	34370	42	161,1	41	28,8	4,8	8600	25	3x560	3000	5,4	79	3510	-	3000	28	54	298
INBE563C10	44,1	34,6	33250	41	214,8	54	33,6	4,8	11500	30	3x560	3000	5,4	79	3510	-	3000	28	76	316
INBE563E10	50,8	39,5	32140	40	268,5	68	38,4	4,8	14400	35	3x560	3000	5,4	79	3510	-	3000	35	76	363
INBE564C10	58,7	45,9	44350	42	287,1	72	43,4	6,2	15400	35	4x560	4000	7,2	80	4510	4000	2000	2x28	2x54	414
INBE565C10	74,1	57	55460	43	359,4	90	53,2	7,6	19300	38	5x560	5000	9	81	5510	5000	2000	2x28	2x54	513

Fin spacing 12 mm																				
INBE562B12	21,4	16,7	23070	41	90,7	27	18,8	3,2	5700	20	2x560	2000	3,6	77	2510	-	2000	22	54	204
INBE562C12	26,5	20,8	22380	40	120,9	36	22	3,2	7600	25	2x560	2000	3,6	77	2510	-	2000	28	54	225
INBE562E12	30,9	24,1	21690	39	151,2	46	25,1	3,2	9600	30	2x560	2000	3,6	77	2510	-	2000	28	54	246
INBE563B12	32,3	25,4	34630	42	136,7	41	28,8	4,8	8600	25	3x560	3000	5,4	79	3510	-	3000	28	54	298
INBE563C12	40	31,7	33600	41	182,3	54	33,6	4,8	11500	30	3x560	3000	5,4	79	3510	-	3000	28	76	316
INBE563E12	46,6	36,5	32580	40	227,9	68	38,4	4,8	14400	35	3x560	3000	5,4	79	3510	-	3000	35	76	363
INBE564C12	53,3	42	44820	42	243,7	72	43,4	6,2	15400	35	4x560	4000	7,2	80	4510	4000	2000	2x28	2x54	414
INBE565C12	67,5	52,4	56050	43	305,1	90	53,2	7,6	19300	38	5x560	5000	9	81	5510	5000	2000	2x28	2x54	513

Model	Capacity* SC2	Capacity* SC3	Air Flow	Air Throw	Surface	Tube volume	Defrost*				Fan motor	Power consumption	Current consumption	Sound Level	Dimensions (see page 31)			Connections		Weight
	kW	kW	m³/h	m	m²		E	HG+E	W	n° x Ømm	W	A	dB(A)		mm	mm	mm	mm	mm	
Fin spacing 4,5 mm	ΔT1= 8K, Tev= -8°C	ΔT1= 7K, Tev= -25°C				kW	kW	l/h	kPa			(5m)	A	B	C	inlet	outlet			
INGE632C45	55,7	41,8	31370	53	375,8	45	22	3,2	9600	30	2x630	3800	6,4	80	2510	-	2000	28	54	314
INGE632E45	62,3	47,1	30300	52	469,8	57	25,1	3,2	11900	30	2x630	3800	6,4	80	2510	-	2000	28	54	351
INGE633C45	84,8	64,2	47110	54	566,6	68	33,6	4,8	14400	35	3x630	5700	9,6	82	3510	-	3000	35	76	446
INGE633E45	93,2	69,9	45510	53	708,3	85	38,4	4,8	18000	38	3x630	5700	9,6	82	3510	-	3000	2x28	2x54	501
INGE634C45	111,7	82,6	62850	55	757,4	90	43,4	6,2	19200	38	4x630	7600	12,8	83	4510	4000	2000	2x28	2x54	580
INGE635C45	140	103,7	78580	56	948,2	112	53,2	7,6	24100	40	5x630	9500	16	84	5510	5000	2000	2x28	2x60	710

Fin spacing 6 mm																				
INRE632C6	49,6	37,8	31890	53	286	45	22	3,2	9600	30	2x630	3800	6,4	80	2510	-	2000	28	54	291
INRE632E6	55,9	42,1	30930	52	357,5	57	25,1	3,2	11900	30	2x630	3800	6,4	80	2510	-	2000	28	54	323
INRE633C6	75,2	57,8	47870	54	431,2	68	33,6	4,8	14400	35	3x630	5700	9,6	82	3510	-	3000	35	76	412
INRE633E6	84,7	64,3	46440	53	539	85	38,4	4,8	18000	38	3x630	5700	9,6	82	3510	-	3000	2x28	2x54	459
INRE634C6	99,8	75,2	63860	55	576,4	90	43,4	6,2	19200	38	4x630	7600	12,8	83	4510	4000	2000	2x28	2x54	534
INRE635C6	125	94,3	79840	56	721,5	112	53,2	7,6	24100	40	5x630	9500	16	84	5510	5000	2000	2x28	2x60	650

Fin spacing 8,5 mm																				
INBE632C85	43,1	33,2	32550	54	206,6	45	22	3,2	9600	30	2x630	3800	6,4	80	2510	-	2000	28	54	272
INBE632E85	49,7	37,8	31740	53	258,2	57	25,1	3,2	11900	30	2x630	3800	6,4	80	2510	-	2000	28	76	298
INBE633C85	65,3	50,7	48910	55	311,4	68	33,6	4,8	14400	35	3x630	5700	9,6	82	2510	-	3000	35	89	382
INBE633E85	75,1	57,6	47650	54	389,3	85	38,4	4,8	18000	38	3x630	5700	9,6	82	3510	-	3000	2x28	2x54	421
INBE634C85	87	66,4	65240	56	416,3	90	43,4	6,2	19200	38	4x630	7600	12,8	83	4510	4000	2000	2x28	2x76	495
INBE635C85	108,9	83,2	81570	57	521,1	112	53,2	7,6	24100	40	5x630	9500	16	84	5510	5000	2000	2x28	2x89	604

Fin spacing 10 mm																			
INBE632C10	39,6	30,8	32800	54	178,1	45	22	3,2	9600	3									

Selection Chart

For an easy thermal selection, we suggest to use our program Palladio or the following diagrams.

FIN SPACING = 4,5 mm
R404A/507 - RH=80-90%

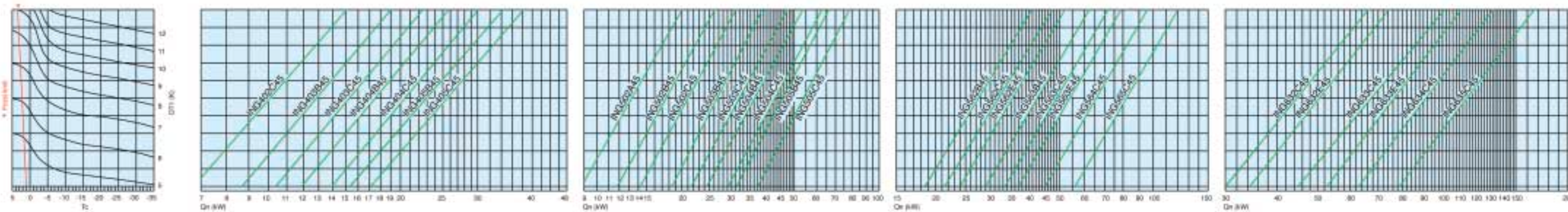

FIN SPACING = 6,0 mm
R404A/507 - RH=80-90%

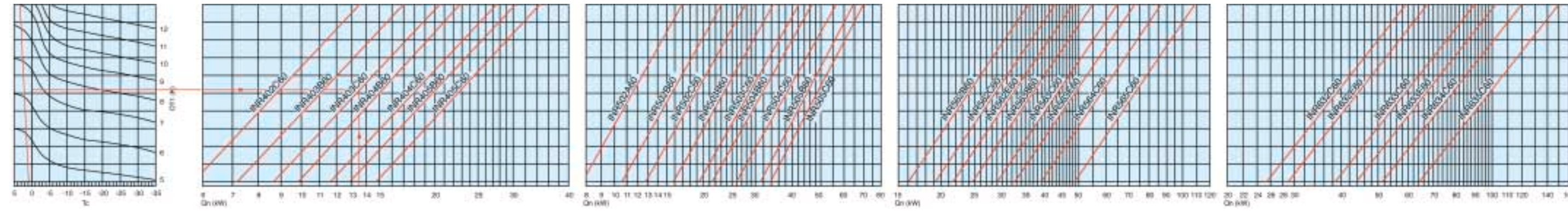

FIN SPACING = 8,5 mm
R404A/507 - RH=80-90%

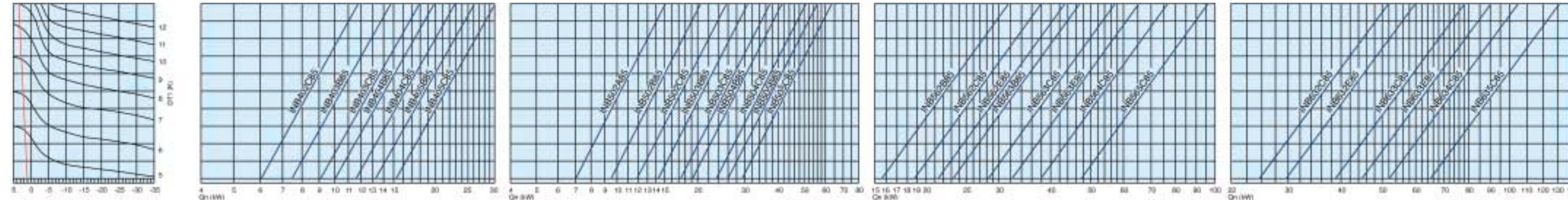

FIN SPACING = 10 mm
R404A/507 - RH=80-90%

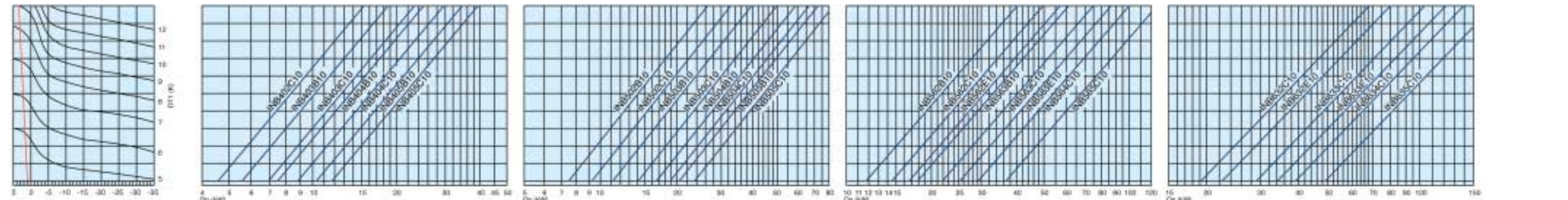

FIN SPACING = 12 mm
R404A/507 - RH=80-90%

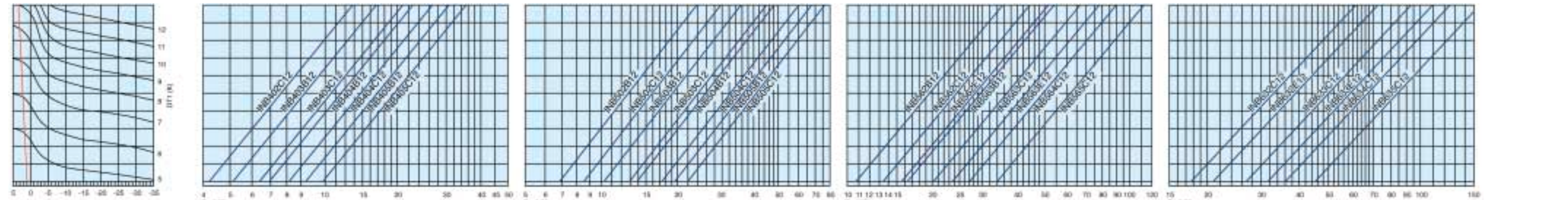

AirMax Brine Ø400

Model	Capacity	Fluid Flow	Fluid Pressure Drop	Circuit	Air Flow	Air Throw	Surface	Tube volume	Defrost			Fan motors	Power consumption	Current consumption	Noise	Dimensions (see page 30)			Connections		Weight	
	kW	m³/h	kPa		m³/h	m	m²	dm³	E	EL	W	n° x Ømm	W	A	dB(A)	mm	mm	mm	mm	mm	kg	
Fin spacing 4,5 mm	Air T _{in} = +2°C / R.H. = 85% 30%Et. Gly. , Temp = -8/-4°C																					
	kW	m³/h	kPa					kW	kW	l/h	kPa			(5m)	A	B	C	inlet	outlet			
INGW402K45	6,9	1,59	15	C	6750	18	64,8	14	7,2	2,7	1310	10	2x400	520	1	59	1660	-	1200	1/2"	1/2"	93
INGW402X45	11,3	2,62	35	C	6360	17	75,6	16	7,2	3,6	1720	10	2x400	520	1	59	1660	-	1200	3/4"	3/4"	99
INGW402Y45	13,5	3,14	56	C	6070	16	86,4	19	9	4,5	1750	10	2x400	520	1	59	1660	-	1200	1/2"	1/2"	107
INGW403K45	16,8	3,9	46	C	10000	18	98	21	10	3,75	2340	10	3x400	780	1,5	61	2260	-	1800	3/4"	3/4"	121
INGW403X45	17	3,95	33	C	9570	17	114,4	25	10	5	2590	10	3x400	780	1,5	61	2260	-	1800	3/4"	3/4"	136
INGW403Y45	20,4	4,74	52	C	9150	16	130,7	28	12,5	6,25	2830	10	3x400	780	1,5	61	2260	-	1800	3/4"	3/4"	151
INGW404K45	21	4,9	35	D	13380	18	131,3	28	14	5,25	3200	10	4x400	1040	2	62	2860	-	2400	1"	1"	155
INGW404X45	22,6	5,27	32	D	12790	17	153,2	33	14	7	3460	10	4x400	1040	2	62	2860	-	2400	1"	1"	172
INGW404Y45	27,2	6,32	51	D	12220	16	175	38	17,5	8,75	3780	10	4x400	1040	2	62	2860	-	2400	1"	1"	189
INGW405K45	29,1	6,79	53	D	16700	18	164,5	35	17,6	6,6	3890	10	5x400	1300	2,5	63	3460	-	3000	1"	1"	188
INGW405X45	31,9	7,43	52	D	15950	17	191,9	41	17,6	8,8	4330	10	5x400	1300	2,5	63	3460	-	3000	1"	1"	208
INGW405Y45	34	7,91	50	D	15300	16	219,4	47	22	11	4650	10	5x400	1300	2,5	63	3460	-	3000	1"	1"	228

Fin spacing 6 mm																						
INRW402K6	5,8	1,35	9,7	C	7050	18	49,5	14	7,2	2,7	1310	10	2x400	520	1	59	1660	-	1200	1/2"	1/2"	89
INRW402X6	10,1	2,33	29,3	C	6640	18	57,8	16	7,2	3,6	1720	10	2x400	520	1	59	1660	-	1200	3/4"	3/4"	95
INRW402Y6	12,5	2,9	48,7	B	6360	17	66	19	9	4,5	1750	10	2x400	520	1	59	1660	-	1200	1/2"	1/2"	103
INRW403K6	15	3,48	38,1	C	10410	18	74,9	21	10	3,75	2340	10	3x400	780	1,5	61	2260	-	1800	3/4"	3/4"	116
INRW403X6	15,1	3,51	27,6	C	10000	18	87,4	25	10	5	2590	10	3x400	780	1,5	61	2260	-	1800	3/4"	3/4"	131
INRW403Y6	18,8	4,37	46	C	9580	17	99,9	28	12,5	6,25	2830	10	3x400	780	1,5	61	2260	-	1800	3/4"	3/4"	145
INRW404K6	22,2	5,18	59,8	C	13870	18	100,3	28	14	5,25	3200	10	4x400	1040	2	62	2860	-	2400	1"	1"	149
INRW404X6	23,9	5,56	51,7	C	13300	18	117	33	14	7	3460	10	4x400	1040	2	62	2860	-	2400	1"	1"	165
INRW404Y6	25,1	5,84	44,6	D	12800	17	133,8	38	17,5	8,75	3780	10	4x400	1040	2	62	2860	-	2400	1"	1"	181
INRW405K6	26,2	6,1	44,1	D	17380	18	125,7	35	17,6	6,6	3890	10	5x400	1300	2,5	63	3460	-	3000	1"	1"	180
INRW405X6	29	6,76	44,5	D	16660	18	146,7	41	17,6	8,8	4330	10	5x400	1300	2,5	63	3460	-	3000	1"	1"	200
INRW405Y6	31,3	7,31	43,7	D	16010	17	167,6	47	22	11	4650	10	5x400	1300	2,5	63	3460	-	3000	1"	1"	219

Fin spacing 7,5 mm																						
INBW402K75	10,1	2,34	55,3	B	7100	19	40,4	14	7,2	2,7	1310	10	2x400	520	1	59	1660	-	1200	1/2"	1/2"	87
INBW402X75	8,9	2,05	23,6	C	6860	18	47,1	16	7,2	3,6	1720	10	2x400	520	1	59	1660	-	1200	3/4"	3/4"	92
INBW402Y75	11,4	2,66	41,6	B	6580	17	53,8	19	9	4,5	1750	10	2x400	520	1	59	1660	-	1200	1/2"	1/2"	100
INBW403K75	13,4	3,09	31,3	C	10720	19	61,1	21	10	3,75	2340	10	3x400	780	1,5	61	2260	-	1800	3/4"	3/4"	113
INBW403X75	17	3,96	56	B	10270	18	71,3	25	10	5	2590	10	3x400	780	1,5	61	2260	-	1800	3/4"	3/4"	127
INBW403Y75	17,2	4	39,3	C	9910	17	81,4	28	12,5	6,25	2830	10	3x400	780	1,5	61	2260	-	1800	3/4"	3/4"	140
INBW404K75	20,1	4,68	50,2	C	14270	19	81,8	28	14	5,25	3200	10	4x400	1040	2	62	2860	-	2400	1"	1"	144
INBW404X75	21,7	5,06	43,8	C	13730	18	95,4	33	14	7	3460	10	4x400	1040	2	62	2860	-	2400	1"	1"	160
INBW404Y75	22,9	5,34	38,1	D	13240	17	109	38	17,5	8,75	3780	10	4x400	1040	2	62	2860	-	2400	1"	1"	176
INBW405K75	23,5	5,48	36,5	D	17880	19	102,5	35	17,6	6,6	3890	10	5x400	1300	2,5	63	3460	-	3000	1"	1"	175
INBW405X75	26,4	6,15	37,8	D	17190	18	119,6	41	17,6	8,8	4330	10	5x400	1300	2,5	63	3460	-	3000	1"	1"	193
INBW405Y75	31,5	7,35	59,2	C	16530	17	136,6	47	22	11	4650	10	5x400	1300	2,5	63	3460	-	3000	1"	1"	212

AirMax Brine Ø500

Model	Capacity	Fluid Flow	Fluid Pressure Drop	Circuit	Air Flow	Air Throw	Surface	Tube volume	Defrost			Fan motors	Power consumption	Current consumption	Noise	Dimensions (see page 30)			Connections		Weight	
	kW	m³/h	kPa		m³/h	m	m²	dm³	E	EL	W	n° x Ømm	W	A	dB(A)	mm	mm	mm	mm	mm	kg	
Fin spacing 4,5 mm	Air T _{in} = +2°C / R.H. = 85% 30%Et. Gly. , Temp = -8/-4°C																					
	kW	m³/h	kPa					kW	kW	l/h	kPa			(5m)	A	B	C	inlet	outlet			
INGW502K45	23,7	5,51	48	D	13870	31	138,8	30	12,8	6,4	3410	10	2x500	1580	2,7	66	2210	-	1700	1"	1"	176
INGW502X45	25,8	6	45	D	13450	30	161,9	35	12,8	8	3720	10	2x500	1580	2,7	66	2210	-	1700	1"	1"	185
INGW502Y45	27,4	6,37	41	D	13050	29	185	40	16	9,6	3940	10	2x500	1580	2,7	66	2210	-	1700	1"	1"	194
INGW503K45	33,5	7,82	36	E	20860	31	209,4	45	22,4	11,2	5280	10	3x500	2370	4,05	68	3060	-	2550	1*1/4	1*1/4	259
INGW503X45	38,7	9,01	43	E	20210	30	244,3	52	22,4	14	5570	15	3x500	2370	4,05	68	3060	-	2550	1*1/4	1*1/4	274
INGW503Y45	42,7	9,96	47	E	19600	29	279,2	60	28	16,8	6140	15	3x500	2370	4,05	68	3060	-	2550	1*1/4	1*1/4	288
INGW504K45	47,3	11,03	44	C	27800	31	280	60	26	10,4	6880	15	4x500	3160	5,4	69	3910	3400	1700	1*1/4	1*1/4	347
INGW504X45	54,8	12,77	56	D	26940	30	326,7	70	26	13	7560	15	4x500	3160	5,4	69	3910	3400	1700	1*1/2	1*1/2	365
INGW504Y45	57,9	13,5	50	D	26160	29	373,3	80	31,2	15,6	8470	15	4x500	3160	5,4	69	3910	3400	1700	1*1/2	1*1/2	384
INGW505K45	60,9	14,23	50	D	34750	31	350,6	75	34	13,6	8940	15	5x500	3950	6,75	70	4760	4250	1700	1*1/2	1*1/2	432
INGW505X45	67,7	15,8	52	D	33700	30	409,1	88	34	17	9550	20	5x500	3950	6,75	70	4760	4250	1700	1*1/2	1*1/2	455
INGW505Y45	73,3	17,12	52	D	32710	29	467,5	100	40,8	20,4	10370	20	5x500	3950	6,75	70	4760	4250	1700	1*1/2	1*1/2	479

Fin spacing 6 mm																						
INRW502K6	21	4,88	39	D	14220	32	106	30	12,8	6,4	3410	10	2x500	1580	2,7	66	2210	-	1700	1"	1"	169
INRW502X6	23,1	5,37	37,2	D	13850	31	123,7	35	12,8	8	3720	10	2x500	1580	2,7	66	2210	-	1700	1"	1"	178
INRW502Y6	27,9	6,5	59,6	C	13460	30	141,4	40	16	9,6	3940	10	2x500	1580	2,7	66	2210	-	1700	1"	1"	187
INRW503K6	33,2	7,74	46,9	D	21350	32	160	45	22,4	11,2	5280	10	3x500	2370	4,05	68	3060	-	2550	1*1/4	1*1/4	249
INRW503X6	37,9	8,84	53,2	D	20770	31	186,7	52	22,4	14	5570	15	3x500	2370	4,05	68	3060	-	2550	1*1/4	1*1/4	264
INRW503Y6	41,8	9,77	57	D	20220	30	213,3	60	28	16,8	6140	15	3x500	2370	4,05	68	3060	-	2550	1*1/4	1*1/4	277
INRW504K6	41,9	9,76	36,2	C	28510	32	214	60	26	10,4	6880	15	4x500	3160	5,4	69	3910	3400	1700	1*1/4	1*1/4	333
INRW504X6	49,6	11,58	47,2	D	27730	31	249,6	70	26	13	7560	15	4x500	3160	5,4	69	3910	3400	1700	1*1/2	1*1/2	350
INRW504Y6	52,9	12,35	42,8	D	27020	30	285,3	80	31,2	15,6												

AirMax Brine Ø560

Model	Capacity		Fluid Flow	Fluid Pressure Drop	Circuit	Air Flow	Air Throw	Surface	Tube volume	Defrost				Fan motors	Power consumption	Current consumption	Noise	Dimensions (see page 30)			Connections		Weight
	kW	m³/h								kPa	m³/h	m	m²					dm³	E	EL	W	n° x Ømm	
Fin spacing 4,5 mm	Air T _{in} = +2°C / R.H. = 85% 30%Et. Gly. , Temp = -8/-4°C							kW	kW	l/h	kPa	(5m)			A	B	C	inlet	outlet				
INGW562K45	35,6	8,3	43,7	E	20530	39	218,2	47	18,8	7,9	5000	10	2x560	2000	3,6	77	2510	-	2000	1"1/4	1"1/4	241	
INGW562X45	40,4	9,43	50,2	C	19790	37	254,6	55	18,8	7,9	5600	15	2x560	2000	3,6	77	2510	-	2000	1"1/2	1"1/2	256	
INGW562Y45	44,2	10,32	54	C	19100	36	291	62	22,0	9,4	6200	15	2x560	2000	3,6	77	2510	-	2000	1"1/2	1"1/2	271	
INGW562Z45	49,2	11,46	54,7	C	17870	33	363,7	78	25,1	14,1	8200	15	2x560	2000	3,6	77	2510	-	2000	1"1/4	1"1/4	300	
INGW563K45	51,4	11,98	36,1	D	30880	39	329	73	28,8	12,0	7800	15	3x560	3000	5,4	79	3510	-	3000	1"1/2	1"1/2	321	
INGW563X45	60,6	14,15	48,3	D	29740	37	383,9	82	28,8	12,0	8600	15	3x560	3000	5,4	79	3510	-	3000	1"1/2	1"1/2	343	
INGW563Y45	64,8	15,11	46,3	D	28720	36	438,7	94	33,6	14,4	9300	20	3x560	3000	5,4	79	3510	-	3000	1"1/2	1"1/2	366	
INGW563Z45	72,7	16,95	48,2	D	26880	33	548,4	118	38,4	21,6	12000	20	3x560	3000	5,4	79	3510	-	3000	1"1/2	1"1/2	410	
INGW564K45	71,1	16,6	41,1	E	41170	39	439,8	94	37,2	15,5	10700	20	4x560	4000	7,2	80	4510	4000	2000	1"1/2	1"1/2	446	
INGW564X45	77,4	18,07	39,1	E	39730	37	513,1	110	37,2	15,5	11600	20	4x560	4000	7,2	80	4510	4000	2000	2"	2"	475	
INGW564Y45	88,4	20,66	50,8	D	38320	36	586,4	126	43,4	18,6	12300	20	4x560	4000	7,2	80	4510	4000	2000	2"	2"	505	
INGW564Z45	98,5	22,96	51,6	D	35880	33	733	157	49,6	27,9	15000	25	4x560	4000	7,2	80	4510	4000	2000	2"	2"	563	
INGW565K45	94	21,95	52,3	D	51430	39	550,6	118	45,6	19,0	13100	20	5x560	5000	9	81	5510	5000	2000	2"	2"	507	
INGW565X45	103,9	24,24	53,8	D	49620	37	642,4	138	45,6	19,0	14600	25	5x560	5000	9	81	5510	5000	2000	2"	2"	544	
INGW565Y45	111,8	26,12	53,4	C	47920	36	734,1	157	53,2	22,8	15800	25	5x560	5000	9	81	5510	5000	2000	2"	2"	580	
INGW565Z45	121,9	28,45	48,3	D	44890	33	917,7	197	60,8	34,2	19500	38	5x560	5000	9	81	5510	5000	2000	2"1/2	2"1/2	654	

Fin spacing 6 mm																						
INRW562K6	35	8,16	55,3	D	21120	40	166,8	47	18,8	7,9	5000	10	2x560	2000	3,6	77	2510	-	2000	1"1/4	1"1/4	231
INRW562X6	36,5	8,52	42	C	20480	39	194,6	55	18,8	7,9	5600	15	2x560	2000	3,6	77	2510	-	2000	1"1/2	1"1/2	245
INRW562Y6	40,5	9,45	46,3	C	19840	37	222,4	62	22,0	9,4	6200	15	2x560	2000	3,6	77	2510	-	2000	1"1/2	1"1/2	260
INRW562Z6	46,2	10,79	49,2	C	18680	35	278	78	25,1	14,1	8200	15	2x560	2000	3,6	77	2510	-	2000	1"1/4	1"1/4	288
INRW563K6	52,5	12,25	53,1	C	31720	40	251,4	73	28,8	12,0	7800	15	3x560	3000	5,4	79	3510	-	3000	1"1/2	1"1/2	308
INRW563X6	57,9	13,5	52	C	30740	39	293,3	82	28,8	12,0	8600	15	3x560	3000	5,4	79	3510	-	3000	1"1/2	1"1/2	329
INRW563Y6	59,4	13,87	39,9	D	29830	37	335,3	94	33,6	14,4	9300	20	3x560	3000	5,4	79	3510	-	3000	1"1/2	1"1/2	351
INRW563Z6	68,1	15,87	42,9	D	28090	35	419,1	118	38,4	21,6	12000	20	3x560	3000	5,4	79	3510	-	3000	1"1/2	1"1/2	394
INRW564K6	70	16,33	52	D	42330	40	336,1	94	37,2	15,5	10700	20	4x560	4000	7,2	80	4510	4000	2000	1"1/2	1"1/2	428
INRW564X6	78,9	18,4	57,6	D	41000	39	392,1	110	37,2	15,5	11600	20	4x560	4000	7,2	80	4510	4000	2000	2"	2"	456
INRW564Y6	81,1	18,93	43,6	D	39790	37	448,1	126	43,4	18,6	12300	20	4x560	4000	7,2	80	4510	4000	2000	2"	2"	485
INRW564Z6	92,6	21,62	46,4	D	37490	35	560,2	157	49,6	27,9	15000	25	4x560	4000	7,2	80	4510	4000	2000	2"	2"	540
INRW565K6	84,1	19,63	43	D	52970	40	420,8	118	45,6	19,0	13100	20	5x560	5000	9	81	5510	5000	2000	2"	2"	487
INRW565X6	94,5	22,08	45,6	D	51320	39	490,9	138	45,6	19,0	14600	25	5x560	5000	9	81	5510	5000	2000	2"	2"	522
INRW565Y6	102,7	23,96	45,9	C	49760	37	561	157	53,2	22,8	15800	25	5x560	5000	9	81	5510	5000	2000	2"	2"	557
INRW565Z6	114,5	26,77	43,4	D	46900	35	701,3	197	60,8	34,2	19500	38	5x560	5000	9	81	5510	5000	2000	2"1/2	2"1/2	628

Fin spacing 7,5 mm																						
INBW562K75	31,5	7,34	45,8	D	21560	42	136	47	18,84	7,9	5000	10	2x560	2000	3,6	77	2510	-	2000	1"1/4	1"1/4	224
INBW562X75	32,9	7,66	34,9	C	20980	40	158,6	55	18,84	7,9	5600	15	2x560	2000	3,6	77	2510	-	2000	1"1/2	1"1/2	238
INBW562Y75	37	8,62	39,4	C	20380	39	181,3	62	21,98	9,4	6200	15	2x560	2000	3,6	77	2510	-	2000	1"1/2	1"1/2	252
INBW562Z75	43,1	10,04	43,4	C	19280	37	226,6	78	25,12	14,1	8200	15	2x560	2000	3,6	77	2510	-	2000	1"1/4	1"1/4	279
INBW563K75	47,2	11,01	44	C	32380	42	205	73	28,8	12,0	7800	15	3x560	3000	5,4	79	3510	-	3000	1"1/2	1"1/2	299
INBW563X75	52,7	12,31	44,3	C	31480	40	239,1	82	28,8	12,0	8600	15	3x560	3000	5,4	79	3510	-	3000	1"1/2	1"1/2	319
INBW563Y75	54	12,6	33,6	D	30640	39	273,3	94	33,6	14,4	9300	20	3x560	3000	5,4	79	3510	-	3000	1"1/2	1"1/2	340
INBW563Z75	68,2	15,91	55,5	C	28960	37	341,6	118	38,4	21,6	12000	20	3x560	3000	5,4	79	3510	-	3000	1"1/2	1"1/2	381
INBW564K75	62,9	14,68	43,1	D	43200	42	274	94	37,2	15,5	10700	20	4x560	4000	7,2	80	4510	4000	2000	1"1/2	1"1/2	415
INBW564X75	72,1	16,82	49,1	D	41980	40	319,6	110	37,2	15,5	11600	20	4x560	4000	7,2	80	4510	4000	2000	2"	2"	442
INBW564Y75	74	17,26	37	D	40870	39	365,3	126	43,4	18,6	12300	20	4x560	4000	7,2	80	4510	4000	2000	2"	2"	470
INBW564Z75	86,2	20,11	40,9	D	38690	37	456,6	157	49,6	27,9	15000	25	4x560	4000	7,2	80	4510	4000	2000	2"	2"	524
INBW565K75	75,2	17,55	35,3	D	54060	42	343	118	45,6	19,0	13100	20	5x560	5000	9	81	5510	5000	2000	2"	2"	472
INBW565X75	85,6	19,97	38,2	D	52550	40	400,2	138	45,6	19,0	14600	25	5x560	5000	9	81	5510	5000	2000	2"	2"	506
INBW565Y75	94,2	22,01	39,5	C	51100	39	457,3	157	53,2	22,8	15800	25	5x560	5000	9	81	5510	5000	2000	2"	2"	540
INBW565Z75	115,8	27	60	C	48330	37	571,7	197	60,8	34,2	19500	38	5x560	5000	9	81	5510	5000	2000	2"1/2	2"1/2	608

AirMax Brine Ø630

Model	Capacity		Fluid Flow	Fluid Pressure Drop	Circuit	Air Flow	Air Throw	Surface	Tube volume	Defrost				Fan motors	Power consumption	Current consumption	Noise	Dimensions (see page 31)			Connections		Weight
	kW	m³/h								kPa	m³/h	m	m²					dm³	E	El	W	n° x Ømm	
Fin spacing 4,5 mm	Air T _{in} = +2°C / R.H. = 85% 30%Et. Gly. , Temp = -8/-4°C							kW	kW	l/h	kPa	(5m)			A	B	C	inlet	outlet				
INGW632K45	45,6	10,61	36	D	31190	52	272,8	58	18,8	11,0	7000	15	2x630	3800	6,4	80	2510	-	2000	1"1/4	1"1/4	313	
INGW632X45	54,7	12,75	48,3	C	30380	51	318,3	68	18,8	11,0	7800	15	2x630	3800	6,4	80	2510	-	2000	1"1/2	1"1/2	332	
INGW632Y45	58,7	13,68	45,1	C	29630	50	363,7	78	22,0	12,6	8400	15	2x630	3800	6,4	80	2510	-	2000	1"1/2	1"1/2	350	
INGW632Z45	70,1	16,37	57,9	D	28220	47	454,7	97	25,1	14,1	11000	20	2x630	3800	6,4	80	2510	-	2000	1"1/2	1"1/2	387	
INGW633K45	70,5	16,45	38,7	E	46820	52	411,3	88	28,8	16,8	10800	20	3x630	5700	9,6	82	3510	-	3000	2"	2"	468	
INGW633X45	78,1	18,22	38	E	45670	51	479,8	103	28,8	16,8	11900	20	3x630	5700	9,6	82	3510	-	3000	2"	2"	497	
INGW633Y45	91,4	21,33	51,4	D	44500	50	548,4	118															

AirMax NH₃ Ø400

Model	Capacity		Air Flow m ³ /h	Air Throw m	Surface m ²	Tube volume dm ³	Defrost				Fan motor n° x Ømm	Power consumption W	Current consumption A	Noise dB(A) (5m)	Dimensions			Connections		Weight kg
	kW	kW					E	EL	W	mm					mm	mm	mm	mm	mm	
	ΔT1= 8K, Tev= -8°C	ΔT1= 7K, Tev= -25°C					kW	kW	l/h	kPa					A	B	C	inlet	outlet	
INGA402A4	11,39	9,3	7200	18	67,2	7	7,2	2,7	1590	10	2x400	520	1	59	1710	-	1200	33	42	93
INGA402B4	13,51	10,28	6780	17	84	9	7,2	3,6	1900	10	2x400	520	1	59	1710	-	1200	33	42	99
INGA402C4	14,9	11,63	6440	16	100,8	11	9	4,5	2130	10	2x400	520	1	59	1710	-	1200	33	42	107
INGA403A4	16,97	14,09	10840	18	101,7	11	10	3,75	2380	10	3x400	780	1,5	61	2310	-	1800	33	42	121
INGA403B4	20,28	15,93	10210	17	127,1	14	10	5	2910	10	3x400	780	1,5	61	2310	-	1800	33	42	136
INGA403C4	22,1	17,27	9700	16	152,5	16	12,5	6,25	3090	10	3x400	780	1,5	61	2310	-	1800	33	42	151
INGA404A4	23,07	18,85	14460	18	136,1	15	14	5,25	3230	10	4x400	1040	2	62	2910	-	2400	33	42	155
INGA404B4	27,54	21,57	13640	17	170,2	18	14	7	3900	10	4x400	1040	2	62	2910	-	2400	33	42	172
INGA404C4	30,16	23,57	12960	16	204,2	22	17,5	8,75	4310	10	4x400	1040	2	62	2910	-	2400	33	42	189
INGA405A4	28,73	22,74	18080	18	170,6	18	17,6	6,6	4000	10	5x400	1300	2,5	63	3510	-	3000	33	42	188
INGA405B4	34,31	26,16	17060	17	213,2	23	17,6	8,8	4850	10	5x400	1300	2,5	63	3510	-	3000	33	42	208
INGA405C4	37,66	28,8	16220	16	255,9	27	22	11	5350	10	5x400	1300	2,5	63	3510	-	3000	33	42	228

Fin spacing 6 mm																					
Model	Capacity	Capacity	Air Flow	Air Throw	Surface	Tube volume	Defrost				Fan motor	Power consumption	Current consumption	Noise	Dimensions			Connections		Weight	
INGRA402A6	9,12	7,55	7600	20	45,5	7	7,2	2,7	1590	10	2x400	520	1	59	1710	-	1200	33	42	91	
INGRA402B6	10,76	8,73	7220	19	56,9	9	7,2	3,6	1900	10	2x400	520	1	59	1710	-	1200	33	42	97	
INGRA402C6	12,02	9,85	6880	18	68,2	11	9	4,5	2130	10	2x400	520	1	59	1710	-	1200	33	42	105	
INGRA403A6	13,27	11,08	11410	20	68,8	11	10	3,75	2380	10	3x400	780	1,5	61	2310	-	1800	33	42	119	
INGRA403B6	15,49	12,9	10870	19	86	14	10	5	2910	10	3x400	780	1,5	61	2310	-	1800	33	42	134	
INGRA403C6	17,32	14,38	10360	18	103,2	16	12,5	6,25	3090	10	3x400	780	1,5	61	2310	-	1800	33	42	148	
INGRA404A6	18,45	15,32	15250	20	92,1	15	14	5,25	3230	10	4x400	1040	2	62	2910	-	2400	33	42	152	
INGRA404B6	21,7	17,86	14510	19	115,2	18	14	7	3900	10	4x400	1040	2	62	2910	-	2400	33	42	169	
INGRA404C6	24,29	19,95	13820	18	138,2	22	17,5	8,75	4310	10	4x400	1040	2	62	2910	-	2400	33	42	185	
INGRA405A6	23,21	18,88	19060	20	115,5	18	17,6	6,6	4000	10	5x400	1300	2,5	63	3510	-	3000	33	42	184	
INGRA405B6	27,31	22,19	18140	19	144,3	23	17,6	8,8	4850	10	5x400	1300	2,5	63	3510	-	3000	33	42	204	
INGRA405C6	32,08	24,96	17300	18	173,2	27	22	11	5350	10	5x400	1300	2,5	63	3510	-	3000	33	42	224	

Fin spacing 7 mm																					
Model	Capacity	Capacity	Air Flow	Air Throw	Surface	Tube volume	Defrost				Fan motor	Power consumption	Current consumption	Noise	Dimensions			Connections		Weight	
INBA402A7	8,33	6,89	7740	20	39,3	7	7,2	2,7	1590	10	2x400	520	1	59	1710	-	1200	33	42	89	
INBA402B7	9,93	8,11	7370	19	49,1	9	7,2	3,6	1900	10	2x400	520	1	59	1710	-	1200	33	42	95	
INBA402C7	11,17	9,13	7050	18	58,9	11	9	4,5	2130	10	2x400	520	1	59	1710	-	1200	33	42	103	
INBA403A7	11,95	10,04	11620	20	59,4	11	10	3,75	2380	10	3x400	780	1,5	61	2310	-	1800	33	42	116	
INBA403B7	14,08	11,79	11110	19	74,3	14	10	5	2910	10	3x400	780	1,5	61	2310	-	1800	33	42	131	
INBA403C7	15,88	13,29	10620	18	89,2	16	12,5	6,25	3090	10	3x400	780	1,5	61	2310	-	1800	33	42	145	
INBA404A7	16,85	13,96	15520	20	79,6	15	14	5,25	3230	10	4x400	1040	2	62	2910	-	2400	33	42	149	
INBA404B7	19,96	16,42	14820	19	99,5	18	14	7	3900	10	4x400	1040	2	62	2910	-	2400	33	42	165	
INBA404C7	22,63	18,49	14160	18	119,4	22	17,5	8,75	4310	10	4x400	1040	2	62	2910	-	2400	33	42	181	
INBA405A7	21,25	17,42	19410	20	99,7	18	17,6	6,6	4000	10	5x400	1300	2,5	63	3510	-	3000	33	42	180	
INBA405B7	25,19	20,61	18530	19	124,7	23	17,6	8,8	4850	10	5x400	1300	2,5	63	3510	-	3000	33	42	200	
INBA405C7	28,59	23,29	17740	18	149,6	27	22	11	5350	10	5x400	1300	2,5	63	3510	-	3000	33	42	219	

Fin spacing 10 mm																					
Model	Capacity	Capacity	Air Flow	Air Throw	Surface	Tube volume	Defrost				Fan motor	Power consumption	Current consumption	Noise	Dimensions			Connections		Weight	
INBA402A10	6,64	5,5	8000	20	28,1	7	7,2	2,7	1590	10	2x400	520	1	59	1710	-	1200	33	42	87	
INBA402B10	8,17	6,67	7670	19	35,1	9	7,2	3,6	1900	10	2x400	520	1	59	1710	-	1200	33	42	92	
INBA402C10	9,12	7,53	7370	18	42,2	11	9	4,5	2130	10	2x400	520	1	59	1710	-	1200	33	42	100	
INBA403A10	9,37	7,94	12000	20	42,5	11	10	3,75	2380	10	3x400	780	1,5	61	2310	-	1800	33	42	113	
INBA403B10	11,23	9,49	11520	19	53,2	14	10	5	2910	10	3x400	780	1,5	61	2310	-	1800	33	42	127	
INBA403C10	12,88	10,85	11090	18	63,8	16	12,5	6,25	3090	10	3x400	780	1,5	61	2310	-	1800	33	42	140	
INBA404A10	13,45	11,15	16010	20	57	15	14	5,25	3230	10	4x400	1040	2	62	2910	-	2400	33	42	144	
INBA404B10	16,1	13,32	15410	19	71,2	18	14	7	3900	10	4x400	1040	2	62	2910	-	2400	33	42	160	
INBA404C10	18,46	15,25	14800	18	85,4	22	17,5	8,75	4310	10	4x400	1040	2	62	2910	-	2400	33	42	176	
INBA405A10	17,22	14,16	20050	20	71,4	18	17,6	6,6	4000	10	5x400	1300	2,5	63	3510	-	3000	33	42	175	
INBA405B10	20,7	16,94	19260	19	89,2	23	17,6	8,8	4850	10	5x400	1300	2,5	63	3510	-	3000	33	42	193	
INBA405C10	23,83	19,42	18530	18	107,1	27	22	11	5350	10	5x400	1300	2,5	63	3510	-	3000	33	42	212	

Fin spacing 12 mm																					
Model	Capacity	Capacity	Air Flow	Air Throw	Surface	Tube volume	Defrost				Fan motor	Power consumption	Current consumption	Noise	Dimensions			Connections		Weight	
INBA402A12	5,89	4,9	8120	20	23,8	7	7,2	2,7	1590	10	2x400	520	1	59	1710	-	1200	33	42	85	
INBA402B12	7,36	6,01	7810	19	29,7	9	7,2	3,6	1900	10	2x400	520	1	59	1710	-	1200	33	42	89	
INBA402C12	8,2	6,81	7530	18	35,7	11	9	4,5	2130	10	2x400	520	1	59	1710	-	1200	33	42	97	
INBA403A12	8,3	7,03	12190	20	36	11	10	3,75	2380	10	3x400	780	1,5	61	2310	-	1800	33	42	110	
INBA403B12	10,01	8,46	11730	19	45	14	10	5	2910	10	3x400	780	1,5	61	2310	-	1800	33	42	123	
INBA403C12	11,56	9,75	11320	18	54	16	12,5	6,25	3090	10	3x400	780	1,5	61	2310	-	1800	33	42	135	
INBA404A12	11,93	9,91	16260	20	48	15	14	5,25	3230	10	4x400	1040	2	62	2910	-	2400	33	42	139	
INBA404B12	14,39	11,93	15690	19	60,2	18	14	7	3900	10	4x400	1040	2	62	2910	-	2400	33	42	155	
INBA404C12	16,6	13,78	15100	18	72,2	22	17,5	8,75	4310	10	4x400	1040	2	62	2910	-	2400	33	42	171	
INBA405A12	15,46	12,66	20350	20	60,4	18	17,6	6,6	4000	10	5x400	1300	2,5	63	3510	-	3000	33	42	170	
INBA405B12	18,67	15,24	19600	19	75,4	23	17,6	8,8	4850	10	5x400	1300	2,5	63	3510	-	3000	33	42	186	
INBA405C12	21,56	17,58	18910	18	90,5	27	22	11	5350	10	5x400	1300	2,5	63	3510	-	3000	33	42	205	

AirMax NH₃ Ø500

Model	Capacity		Air Flow m ³ /h	Air Throw m	Surface m ²	Tube volume dm ³	Defrost				Fan motor n° x Ømm	Power consumption W
-------	----------	--	-------------------------------	----------------	---------------------------	--------------------------------	---------	--	--	--	-----------------------	------------------------

AirMax NH₃ Ø560

Model	Capacity		Air Flow m ³ /h	Air Throw m	Surface m ²	Tube volume dm ³	Defrost				Fan motor n° x Ømm	Power consumption W	Current consumption A	Noise dB(A)	Dimensions			Connections		Weight kg
	kW	kW					E	EL	W	mm					mm	mm	mm	mm	mm	
	ΔT1= 8K, Tev= -8°C	ΔT1= 7K, Tev= -25°C					kW	kW	l/h	kPa					A	B	C	inlet	outlet	
INGA562B4	43,52	34,08	20850	37	282,9	30	18,84	7,85	5600	15	2x560	2000	6.2/3.6	77	2510	-	2000	33	42	256
INGA562C4	47,75	37,09	20050	36	339,5	36	21,98	9,42	6200	15	2x560	2000	6.2/3.6	77	2510	-	2000	33	42	271
INGA562D4	50,65	39,25	19300	33	396	42	25,12	14,13	8200	15	2x560	2000	6.2/3.6	77	2510	-	2000	33	48	300
INGA563B4	65,81	50,14	31330	37	426,5	46	28,8	12	8600	15	3x560	3000	9.3/5.4	79	3510	-	3000	2x33	2x42	343
INGA563C4	72,36	55,28	30130	36	511,8	55	33,6	14,4	9300	20	3x560	3000	9.3/5.4	79	3510	-	3000	2x33	2x42	366
INGA563D4	77,22	59,12	29010	33	597,1	64	38,4	21,6	12000	20	3x560	3000	9.3/5.4	79	3510	-	3000	2x33	2x42	410
INGA564B4	84,76	61,81	41800	37	570,1	61	37,2	15,5	11600	20	4x560	4000	12.4/7.2	80	4510	4000	2000	2x33	2x42	475
INGA564C4	93,73	68,74	40200	36	684,1	73	43,4	18,6	12300	20	4x560	4000	12.4/7.2	80	4510	4000	2000	2x33	2x42	505
INGA564D4	100,52	74,16	38710	33	798,1	85	49,6	27,9	15000	25	4x560	4000	12.4/7.2	80	4510	4000	2000	2x33	2x42	563
INGA565B4	109,18	82,02	52270	37	713,7	76	45,6	19	14600	25	5x560	5000	15.5/9.0	81	5510	5000	2000	2x33	2x42	544
INGA565C4	120,23	90,66	50280	36	856,4	92	53,2	22,8	15800	25	5x560	5000	15.5/9.0	81	5510	5000	2000	2x33	2x48	580
INGA565D4	128,46	97,21	48420	33	999,1	107	60,8	34,2	19500	38	5x560	5000	15.5/9.0	81	5510	5000	2000	2x33	2x48	654

Fin spacing 6 mm																				
Model	Capacity kW	Capacity kW	Air Flow m ³ /h	Air Throw m	Surface m ²	Tube volume dm ³	E	EL	W	Fan motor n° x Ømm	Power consumption W	Current consumption A	Noise dB(A)	Dimensions mm	Dimensions mm	Dimensions mm	Connections mm	Connections mm	Weight kg	
INGRA562B6	33,58	27,66	21770	41	191,5	30	18,84	7,85	5200	10	2x560	2000	6.2/3.7	77	2510	-	2000	33	42	251
INGRA562C6	37,51	30,95	21070	39	229,8	36	21,98	9,42	5700	15	2x560	2000	6.2/3.8	77	2510	-	2000	33	42	265
INGRA562D6	42,81	33,62	20420	38	268,1	42	25,12	14,13	6200	15	2x560	2000	6.2/3.9	77	2510	-	2000	33	48	294
INGRA563B6	52,19	42,34	32710	41	288,7	46	28,8	12	7800	15	3x560	3000	9.3/5.4	79	3510	-	3000	2x33	2x42	336
INGRA563C6	61,38	47,65	31660	39	346,4	55	33,6	14,4	8400	15	3x560	3000	9.3/5.4	79	3510	-	3000	2x33	2x42	359
INGRA563D6	67,07	51,9	30690	38	404,2	64	38,4	21,6	9600	20	3x560	3000	9.3/5.4	79	3510	-	3000	2x33	2x42	402
INGRA564B6	68,4	53,54	43620	41	385,9	61	37,2	15,5	10400	20	4x560	4000	12.4/7.2	80	4510	4000	2000	2x33	2x42	466
INGRA564C6	80,72	60,66	42240	39	463,1	73	43,4	18,6	11400	20	4x560	4000	12.4/7.2	80	4510	4000	2000	2x33	2x42	495
INGRA564D6	88,44	66,64	40940	38	540,2	85	49,6	27,9	13000	20	4x560	4000	12.4/7.2	80	4510	4000	2000	2x33	2x42	552
INGRA565B6	87,04	69,81	54500	41	483,1	76	45,6	19	13300	20	5x560	5000	15.5/9.0	81	5510	5000	2000	2x33	2x42	533
INGRA565C6	102,44	78,8	52810	39	579,7	92	53,2	22,8	14500	25	5x560	5000	15.5/9.0	81	5510	5000	2000	2x33	2x48	569
INGRA565D6	112,01	86,26	51200	38	676,3	107	60,8	34,2	16100	25	5x560	5000	15.5/9.0	81	5510	5000	2000	2x33	2x48	641

Fin spacing 7 mm																				
Model	Capacity kW	Capacity kW	Air Flow m ³ /h	Air Throw m	Surface m ²	Tube volume dm ³	E	EL	W	Fan motor n° x Ømm	Power consumption W	Current consumption A	Noise dB(A)	Dimensions mm	Dimensions mm	Dimensions mm	Connections mm	Connections mm	Weight kg	
INBA562B7	30,51	25,29	22080	41	165,4	30	18,84	7,85	5200	10	2x560	2000	6.2/3.7	77	2510	-	2000	33	42	245
INBA562C7	34,54	28,55	21430	39	198,4	36	21,98	9,42	5700	15	2x560	2000	6.2/3.8	77	2510	-	2000	33	42	260
INBA562D7	39,83	31,34	20800	38	231,5	42	25,12	14,13	6200	15	2x560	2000	6.2/3.9	77	2510	-	2000	33	48	288
INBA563B7	48,05	39,17	33170	41	249,3	46	28,8	12	7800	15	3x560	3000	9.3/5.4	79	3510	-	3000	2x33	2x42	329
INBA563C7	54,69	44,33	32210	39	299,2	55	33,6	14,4	8400	15	3x560	3000	9.3/5.4	79	3510	-	3000	2x33	2x42	351
INBA563D7	62,79	48,66	31260	38	349	64	38,4	21,6	9600	20	3x560	3000	9.3/5.4	79	3510	-	3000	2x33	2x42	394
INBA564B7	63,53	50,09	44230	41	333,3	61	37,2	15,5	10400	20	4x560	4000	12.4/7.2	80	4510	4000	2000	2x33	2x42	456
INBA564C7	75,39	57,11	42960	39	399,9	73	43,4	18,6	11400	20	4x560	4000	12.4/7.2	80	4510	4000	2000	2x33	2x42	485
INBA564D7	83,16	63,14	41700	38	466,6	85	49,6	27,9	13000	20	4x560	4000	12.4/7.2	80	4510	4000	2000	2x33	2x42	540
INBA565B7	80,32	64,92	55290	41	417,2	76	45,6	19	13300	20	5x560	5000	15.5/9.0	81	5510	5000	2000	2x33	2x42	522
INBA565C7	95,51	73,78	53660	39	500,7	92	53,2	22,8	14500	25	5x560	5000	15.5/9.0	81	5510	5000	2000	2x33	2x48	557
INBA565D7	105	81,12	52150	38	584,1	107	60,8	34,2	16100	25	5x560	5000	15.5/9.0	81	5510	5000	2000	2x33	2x48	628

Fin spacing 10 mm																				
Model	Capacity kW	Capacity kW	Air Flow m ³ /h	Air Throw m	Surface m ²	Tube volume dm ³	E	EL	W	Fan motor n° x Ømm	Power consumption W	Current consumption A	Noise dB(A)	Dimensions mm	Dimensions mm	Dimensions mm	Connections mm	Connections mm	Weight kg	
INBA562B10	24,27	20,34	22620	41	118,4	30	18,84	7,85	4800	10	2x560	2000	6.2/3.7	77	2510	-	2000	33	42	238
INBA562C10	27,95	23,35	22090	39	142	36	21,98	9,42	5400	15	2x560	2000	6.2/3.8	77	2510	-	2000	33	42	252
INBA562D10	31,21	26	21550	38	165,7	42	25,12	14,13	7600	15	2x560	2000	6.2/3.9	77	2510	-	2000	33	48	279
INBA563B10	39,28	32,01	33950	41	178,5	46	28,8	12	7600	15	3x560	3000	9.3/5.4	79	3510	-	3000	2x33	2x42	319
INBA563C10	45,34	36,79	33150	39	214,1	55	33,6	14,4	8200	15	3x560	3000	9.3/5.4	79	3510	-	3000	2x33	2x42	340
INBA563D10	50,63	41,01	32340	38	249,8	64	38,4	21,6	10500	20	3x560	3000	9.3/5.4	79	3510	-	3000	2x33	2x42	381
INBA564B10	52,46	42,17	45310	41	238,5	61	37,2	15,5	10000	20	4x560	4000	12.4/7.2	80	4510	4000	2000	2x33	2x42	442
INBA564C10	60,63	48,66	44250	39	286,2	73	43,4	18,6	11100	20	4x560	4000	12.4/7.2	80	4510	4000	2000	2x33	2x42	470
INBA564D10	67,74	54,38	43150	38	334	85	49,6	27,9	13000	20	4x560	4000	12.4/7.2	80	4510	4000	2000	2x33	2x42	524
INBA565B10	65,84	53,58	56630	41	298,6	76	45,6	19	12800	20	5x560	5000	15.5/9.0	81	5510	5000	2000	2x33	2x42	506
INBA565C10	76,04	61,61	55310	39	358,3	92	53,2	22,8	13900	20	5x560	5000	15.5/9.0	81	5510	5000	2000	2x33	2x48	546
INBA565D10	85,08	68,73	53960	38	418,1	107	60,8	34,2	17800	25	5x560	5000	15.5/9.0	81	5510	5000	2000	2x33	2x48	608

Fin spacing 12 mm																				
Model	Capacity kW	Capacity kW	Air Flow m ³ /h	Air Throw m	Surface m ²	Tube volume dm ³	E	EL	W	Fan motor n° x Ømm	Power consumption W	Current consumption A	Noise dB(A)	Dimensions mm	Dimensions mm	Dimensions mm	Connections mm	Connections mm	Weight kg	
INBA562B12	21,59	18,12	22870	41	100,1	30	18,84	7,85	5600	15	2x560	2000	6.2/3.6	77	2510	-	2000	33	42	231
INBA562C12	25,03	20,95	22380	39	120,1	36	21,98	9,42	6200	15	2x560	2000	6.2/3.6	77	2510	-	2000	33	42	244
INBA562D12	28,14	23,49	21890	38	140,1	42	25,12	14,13	7600	15	2x560	2000	6.2/3.6	77	2510	-	2000	33	48	270
INBA563B12	35,17	28,72	34310	41	150,9	46	28,8	12	8600	15	3x560	3000	9.3/5.4	79	3510	-	3000	2x33	2x42	309
INBA563C12	40,76	33,22	33590	39	181,1	55	33,6	14,4	9300	20	3x560	3000	9.3/5.4	79	3510	-	3000	2x33	2x42	329
INBA563D12	45,82	37,28	32830	38	211,3	64	38,4	21,6	10500	20	3x560	3000	9.3/5.4	79	3510	-	3000	2x33	2x42	368
INBA564B12	47,4	38,23	45780	41	201,7	61	37,2	15,5	11600	20	4x560	4000	12.4/7.2	80	4510	4000	2000	2x33	2x42	428
INBA564C12																				

AirMax Ø400

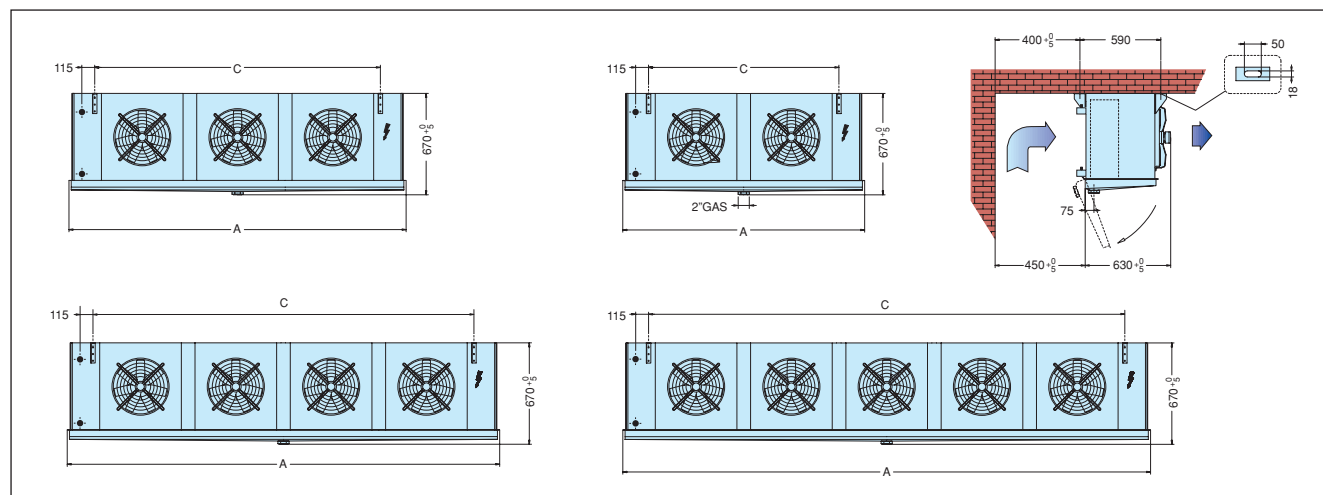

AirMax Ø630

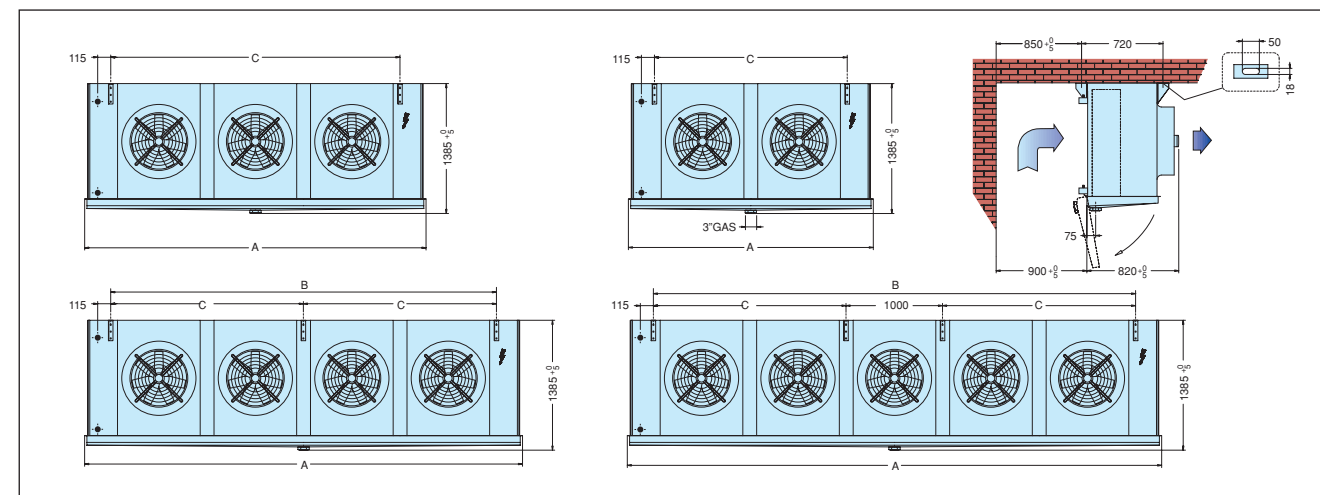

AirMax Ø500

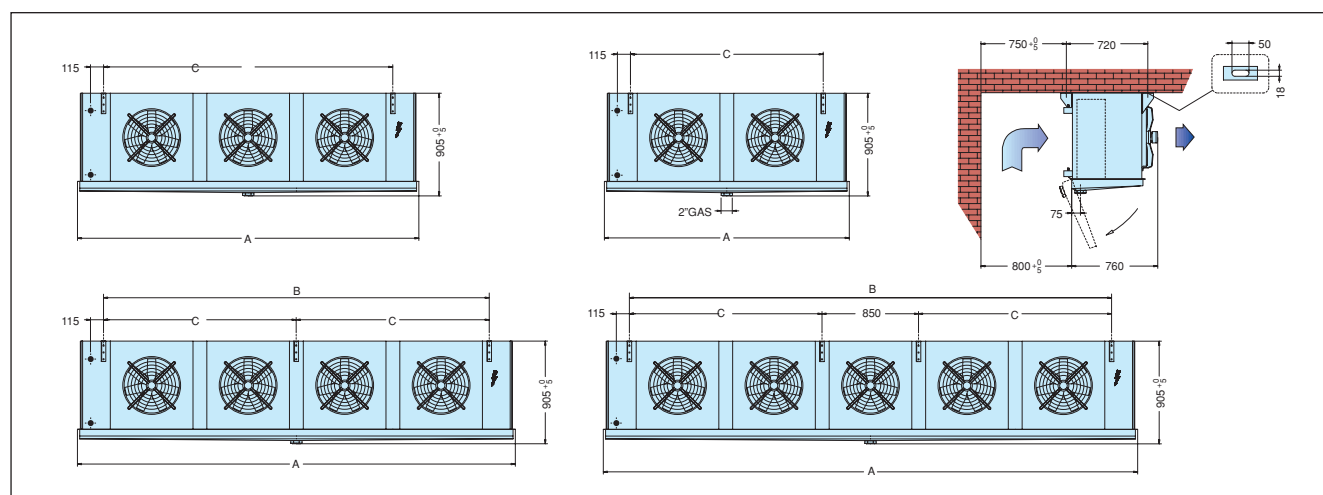

Options

Mounting feet

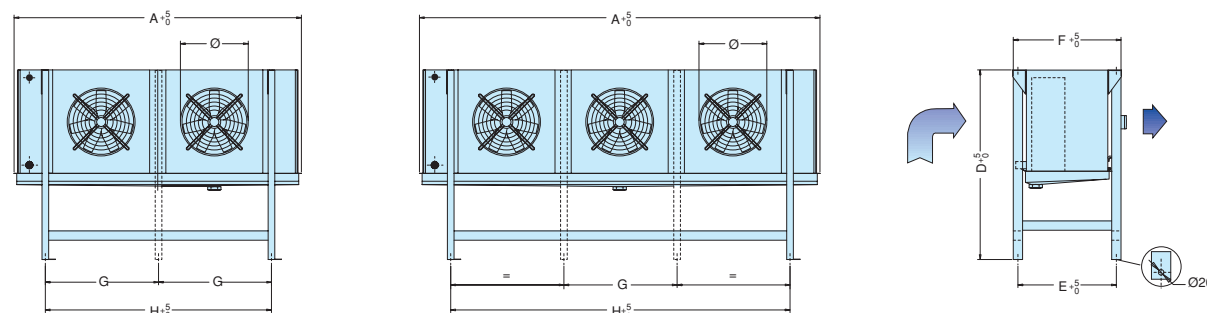

Feets in hot dip galvanised steel

AirMax Ø560

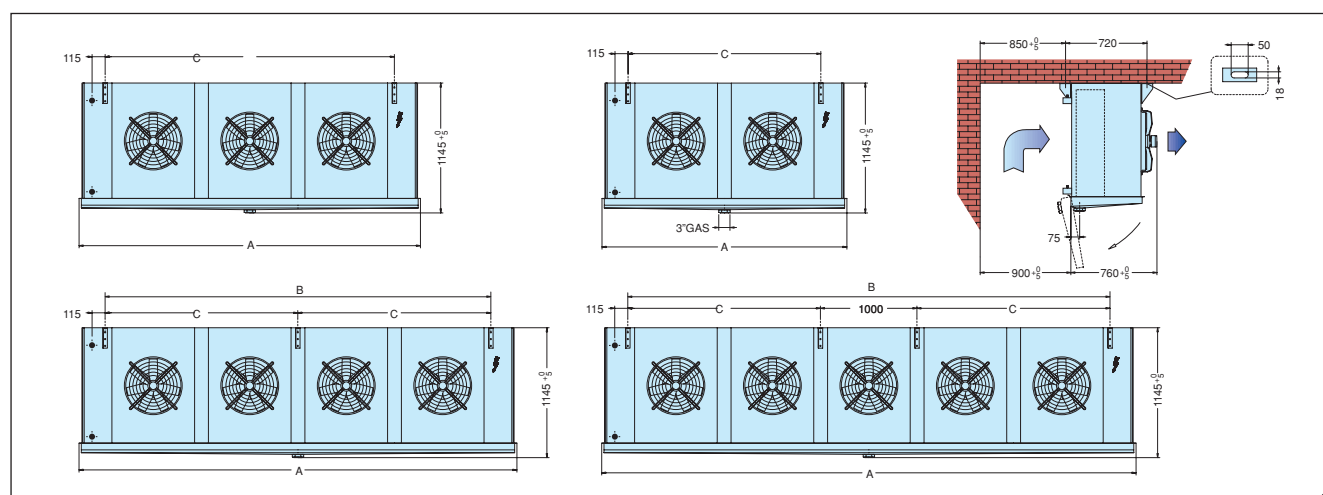

Model	n°xØ	A	D	E	F	G	H
AirMax400	2x400	1710	1420	610	690	-	1200
AirMax400	4x400	2910	1420	610	690	1200	2400
AirMax500	2x500	2210	1660	740	820	-	1700
AirMax500	4x500	3910	1660	740	820	1700	3400
AirMax560	2x560	2510	1660	740	820	-	2000
AirMax560	4x560	4510	1660	740	820	2000	4000
AirMax630	2x630	2510	1900	740	820	-	2000
AirMax630	4x630	4510	1900	740	820	2000	4000

Model	n°xØ	A	D	E	F	G	H
AirMax400	3x400	2310	1420	610	690	-	1800
AirMax400	5x400	3510	1420	610	690	600	3000
AirMax500	3x500	3060	1660	740	820	-	2550
AirMax500	5x500	4760	1660	740	820	850	4250
AirMax560	3x560	3510	1660	740	820	-	3000
AirMax560	5x560	5510	1660	740	820	1000	5000
AirMax630	3x630	3510	1900	740	820	-	3000
AirMax630	5x630	5510	1900	740	820	1000	5000

Cowls air throw

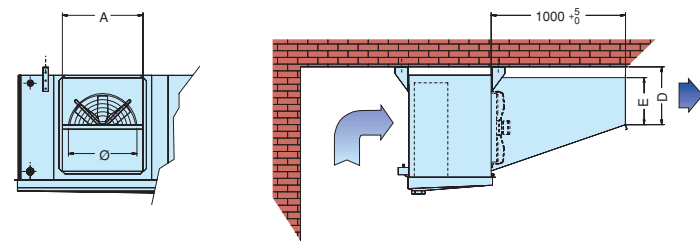

Model	Ø	A	E	D
AirMax400	400	-	-	-
AirMax500	500	600	350	430
AirMax560	560	800	500	580
AirMax630	630	800	500	580

Airsock ring

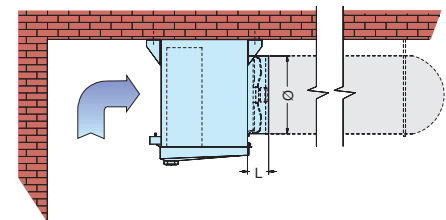

Model	Ø	L
AirMax400	465	140
AirMax500	545	140
AirMax560	630	140
AirMax630	685	140

- Applications:**
- Flower and fruit storage areas
 - Supermarket
 - Bakeries
 - Meat and meat-processing operations

The textile sock is not supplied by Alfa Laval

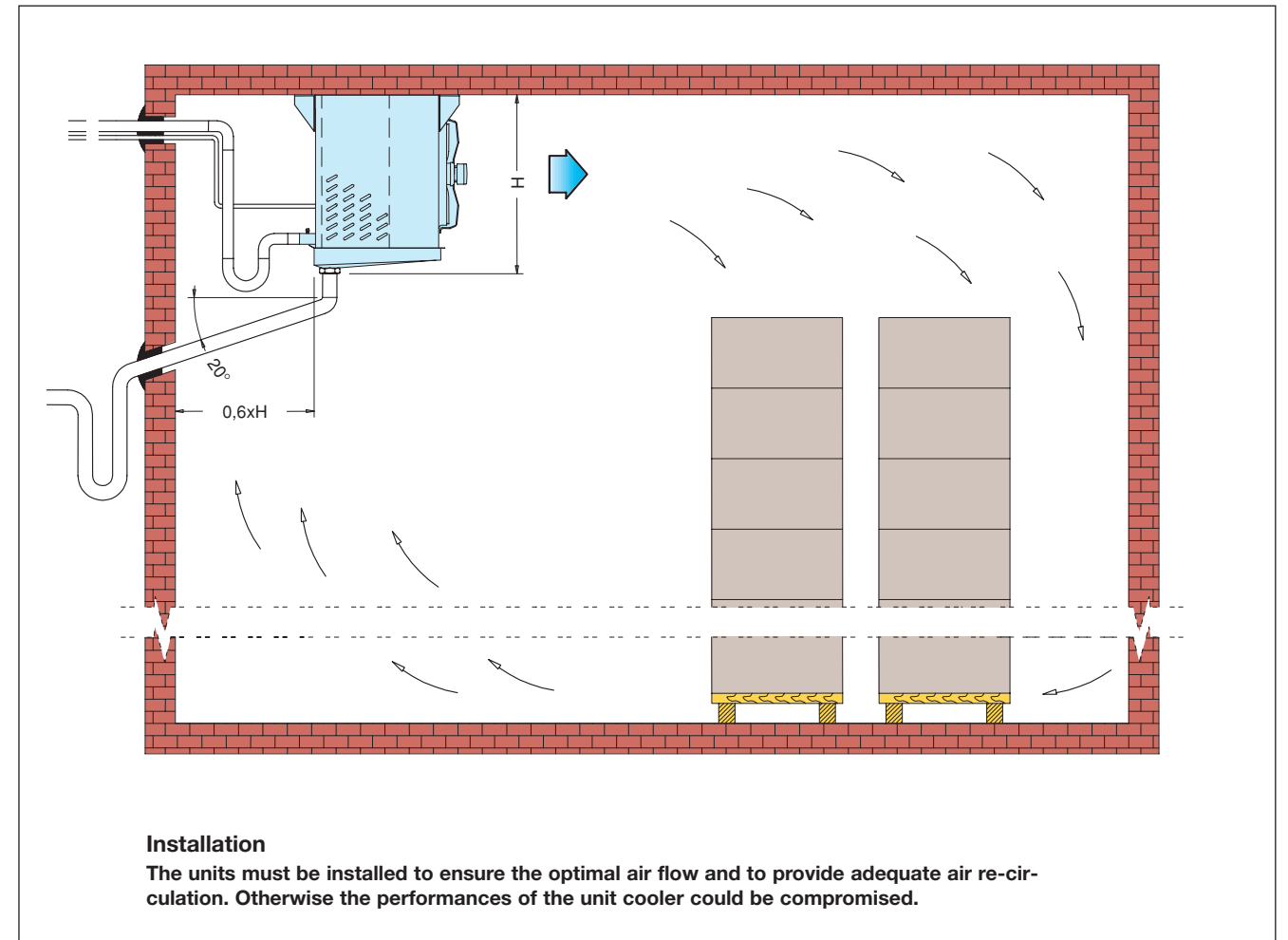

Installation

The units must be installed to ensure the optimal air flow and to provide adequate air re-circulation. Otherwise the performances of the unit cooler could be compromised.

Water Defrost

Model	W	H
AirMax400	1" 1/4	2"
AirMax500	1" 1/4	2"
AirMax560	1" 1/4	3"
AirMax630	1" 1/4	3"

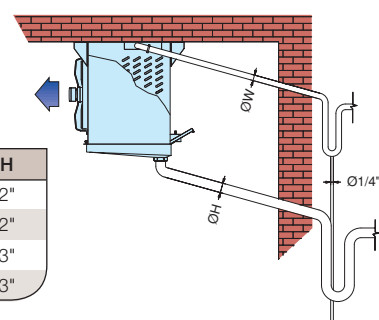

- Applications:**
- Cold room temperature down to -5°C, water defrost
 - Cold room temperature down to -25°C, water in the coil + "E" defrost in the drip tray and on the deflector

Fan ring heater

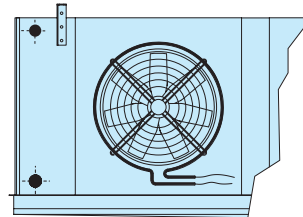

Model	Ø	Volt	Watt
AirMax400	405	230	350
AirMax500	505	230	450
AirMax560	640	230	600
AirMax630	640	230	600

- Applications:**
- Used to prevent fans from jamming by ice or frost build up

Insulation drip-tray

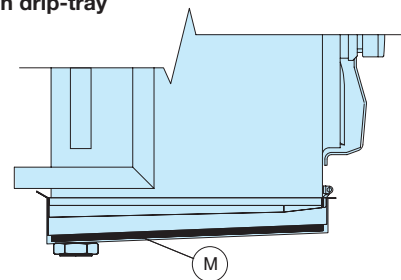

Material (M)	Thickness
Polyetilene	1/2"
Armaflex	1/2"

- Applications:**
- Cold room with high RH
 - HG and E defrost

Hot gas defrost (HG)

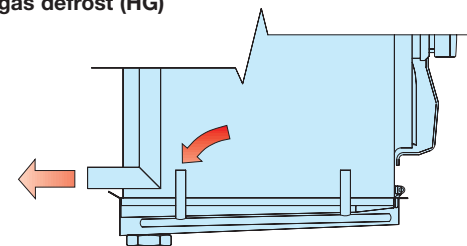

Optional

- Coil epoxy coating
- Cataphoresy treatment
- Epoxy pre-painted fins
- Stainless steel tubes
- Stainless steel casing
- Casing manufactured from pre-painted (RAL 9010) aluminum sheets
- Motors cabling
- Insulated drip tray
- Fan cowling hinged
- Peripheral fan cowling heater
- Cowl air throw
- Air sock adapter ring
- 120° elbow reducer for drip tray outlet
- Single-phase motor fans 230V-50Hz

Defrost

- All defrost systems and components, have been optimized in order to minimize the defrost time and energy consumption. The available defrost systems are the following:
- Electric (coil + drip tray)
 - Low electric (coil + drip tray)
 - Water
 - Hot gas
 - Water defrost + electric defrost on drip tray
 - Hot gas defrost coil + electric defrost on drip tray

On request heater element in the drain line RS = 100 W.

Series	ING	INR	INB
Product	Fruits / Vegetables	Meat / Fish	Frozen food
Room temperature	10 ÷ 0°C	0 ÷ -7°C	-18 ÷ -25°C
Fin spacing DX evaporator version	4,5 mm	6 mm	8,5/10-12 mm
Fin spacing Brine version	4,5 mm	6 mm	7,5 mm

Ordering Code	
Model (I)	ING • INR • INB Industrial unit cooler
Application (II)	E = Direct expansion evaporator • W = Brine unit cooler • A = Ammonia pump evaporator
Fans (III)	Diameter and Number
Coil size (IV)	A • B • C • E • K • X • Y • Z
Fin spacing (V)	4,5 • 6 • 7,5 • 8,5 • 10 • 12
Defrost (VI)	E = Electric • EL = Electric Low • HG = Hot gas • W-E = Water + Electric • HG-E = Hot gas + Electric

Example: INR E 503 C60 E
(I) (II) (III) (IV) (V) (VI)



Centrifugal Unit Coolers

ISC

Application

Series with centrifugal fans, designed for sock applications and mainly in working and packaging rooms, where it's basic to have low air velocity and uniform hygrometric conditions. Cold room volumes from 150 to 1500 m³. Units designed for an easy maintenance with immediate access to the inspection areas.

This series is available as: DX evaporator, NH₃ pump evaporator and Brine unit cooler.

Coil

Coil manufactured from corrugated aluminium fins and copper tubes nominal diameter 16 mm.

Casing

It's manufactured from aluminium sheets, suitable for applications where a high degree of hygiene is required.

Fans

Three-phase motor 400V-50/60Hz, 4 poles. Protection class IP 55. External static pressure available standard 150 Pa. Two V belts drive.

Defrost

As optional are available the following defrost: electric (E), hot gas (HG), water (W), hot gas in the coil and electric in the drip tray (HG-E), water plus electric (W-E).

Optional

- Aluminium fins epoxy painted
- Cataphoresis treatment
- Stainless steel tubes
- Casing in stainless steel
- External static pressure available 50, 100, 200 Pa
- Filters

Series	ISC
Product	Dairy products
Room temperature	12 ÷ 0°C
Fin spacing	4,2mm

Ordering Code	
Model (I)	ISC Industrial sock cooling
Application (II)	S = Direct expansion evaporator • P = Brine unit cooler • A = Ammonia pump evaporator
Defrost (VI)	A = Air • E = Electric • HG = Hot gas • W = Water • HG-E = Hot gas in the coil and electric in the drip tray • W-E = Water and electric in the drip tray

Example: ISC 1912 S-E
(I) (II)(VI)

• ISC-S • ISC-P

Model	Capacity *		Air Flow	Static pressure	Surface	Tube volume	Defrost			Fan motors 230/400V 3/50 Hz			Noise	Dimensions								Connections		Weight				
	SC1	SC2					E	HG+E	W	n°	kW	A		min ⁻¹	dB(A)	mm	mm	mm	mm	mm	mm	mm	mm		mm	mm	mm	mm
ISC-1412	18,4	12,5	9230	150	81,5	19	7,85	1,6	3050	12	1	1,25	3	600	52	2450	920	1010	750	2000	-	490	700	404	471	5/8"SAE	35	150
ISC-1612	24	16,4	9140	150	122,3	29	11	1,6	4520	16	1	1,25	3	600	52	2450	920	1010	750	2000	-	490	700	404	471	22	35	200
ISC-1912	29,8	20,5	9000	150	183,4	44	15,7	1,6	6800	18	1	1,25	3	630	52	2450	920	1010	750	2000	-	490	700	404	471	28	42	325
ISC-1416	26,7	18	14240	150	108,7	26	9,5	1,6	4050	16	1	1,83	4	530	56	2450	1160	1135	750	2000	-	585	950	478	557	28	42	190
ISC-1616	35	23,8	14060	150	163	39	14,2	1,6	4520	16	1	1,83	4	560	56	2450	1160	1135	750	2000	-	585	950	478	557	35	48	270
ISC-1916	43,8	30	13800	150	244,6	58	18,9	1,6	9080	25	1	1,83	4	560	56	2450	1160	1135	750	2000	-	585	950	478	557	35	48	425
ISC-2416	53,8	36,2	28490	150	219	51	18,6	3,1	8100	23	2	3,66	8	530	59	4450	1160	1135	750	4000	2000	595	950	478	557	35	54	370
ISC-2616	70,4	47,9	28130	150	328,6	77	27,9	3,1	12200	35	2	3,66	8	560	59	4450	1160	1135	750	4000	2000	595	950	478	557	35	54	550
ISC-2916	88	60,3	27610	150	492,8	115	37,2	3,1	18280	35	2	3,66	8	560	59	4450	1160	1135	750	4000	2000	595	950	478	557	35	60	820

* Nominal capacity according to ENV328 and Eurovent rules (refrigerant R404A, DT1 = TINair - Tev). Use external equalized thermostatic expansion valve.

Model	Capacity **	Fluid flow rate	Pressure drop	Air Flow	Static pressure	Surface	Tube volume	Defrost			Fan motors 230/400V 3/50 Hz			Noise	Dimensions								Connections		Weight				
								E	W	n°	kW	A	min ⁻¹		dB(A)	mm	mm	mm	mm	mm	mm	mm	mm	mm		mm	mm	mm	mm
ISC-1412	13,9	3,3	52	9230	150	81,5	20	7,85	3050	12	1	1,25	3	600	52	2450	920	1010	750	2000	-	490	700	404	471	1"	1"	150	
ISC-1612	18,4	4,3	41	9140	150	122,3	30	11	4520	16	1	1,25	3	600	52	2450	920	1010	750	2000	-	490	700	404	471	1 1/2"	1 1/2"	200	
ISC-1912	23	5,4	30	9000	150	183,4	45	15,7	6800	18	1	1,25	3	630	52	2450	920	1010	750	2000	-	490	700	404	471	1 1/2"	1 1/2"	325	
ISC-1416	18,8	4,4	38	14240	150	108,7	27	9,5	4050	16	1	1,83	4	530	56	2450	1160	1135	750	2000	-	585	950	478	557	1"	1"	190	
ISC-1616	26,9	6,3	49	14060	150	163	40	14,2	4520	16	1	1,83	4	560	56	2450	1160	1135	750	2000	-	585	950	478	557	1 1/2"	1 1/2"	270	
ISC-1916	34,1	8	36	13800	150	244,6	60	18,9	9080	25	1	1,83	4	560	56	2450	1160	1135	750	2000	-	585	950	478	557	2"	2"	425	
ISC-2416	37,6	8,8	36	28490	150	219	53	18,6	8100	23	2	3,66	8	530	59	4450	1160	1135	750	4000	2000	595	950	478	557	1 1/2"	1 1/2"	370	
ISC-2616	53,8	12,6	46	28130	150	328,6	79	27,9	12200	35	2	3,66	8	560	59	4450	1160	1135	750	4000	2000	595	950	478	557	2"	2"	550	
ISC-2916	68,1	15,9	34	27610	150	492,8	117	37,2	18280	35	2	3,66	8	560	59	4450	1160	1135	750	4000	2000	595	950	478	557	2"	2"	820	

** Nominal capacity referring to inlet Air temperature 8°C, Liquid temp. IN/OUT = -2/+2°C; R.H. = 85%, Ethylen Glycol 30%

